



AUSTERE - MAINS POWER



Installation
& maintenance
instructions.

SPL

General Information

- Designed for indoor use only. Do not expose to elements of nature.
- All plumbing and electrical connections must be made in accordance with AUS / NZ standards.

Warnings

- Read all instructions before attempting to install this system. It is recommended a qualified & registered plumber completes the install.
- Ensure pipe work is thoroughly flushed before installing the solenoid assembly. Solenoid components are susceptible to debris and require additional flushing compared to a standard plumbing fixture.
- Consideration should be given to any regulations relating to an air gap, an air break or double check valve to protect against back flow.

Operating Instructions and Parts Manual

Please read carefully before attempting to assemble, install, operate or maintain the product described. Protect yourself and others by observing all safety information. Failure to comply with instructions could result in personal injury and/or property damage. Retain instructions for future reference.

Sanela Austere Sensor Tap

Sensor activated tapware for cold and pre-mixed water. High quality electronics combined with elegant aesthetics.

Specifications

Finish	Chrome
Water Temperature	For cold or premixed water (thermostatic mixing valve available)
Power Supply	24V DC (230V AC into power supply)
Control	Infra-red sensor
Operating Voltage	24V DC, 7W
Active Range	Standard 0.13 - 0.19 m, START/STOP program 0.25 - 7.75secs
Recommended Pressure	0.1 - 0.6 Mpa (1-6 Bar)
Rate of Flow	3.8 l/min (6 l/min or 1.9L/m available on request)
Water Inlet	Male thread G 1/2"
Dimensions	Height 152mm, Depth 145mm, Tap Diameter Ø 54, Hole Ø 35mm, Nosing 97mm, Discharge Height 128mm
Warranty	24 Months

Planning

- Ensure an appropriate piping design (sizing etc). This will eliminate issues arising from flow, pressure and water hammering.
- Where appropriate install necessary filters, water hammering arrestors and water pressure reducing valves (recommended pressure 1 to 6 bar). This will minimise future maintenance.
- Install the angle valve to enable ease of future maintenance.

Tempered Water

- An appropriate thermostatic mixing valve (TMV3) should be installed to ensure a safe regulated water temperature. These are available from SPL – SST THERMO VALVE

Components

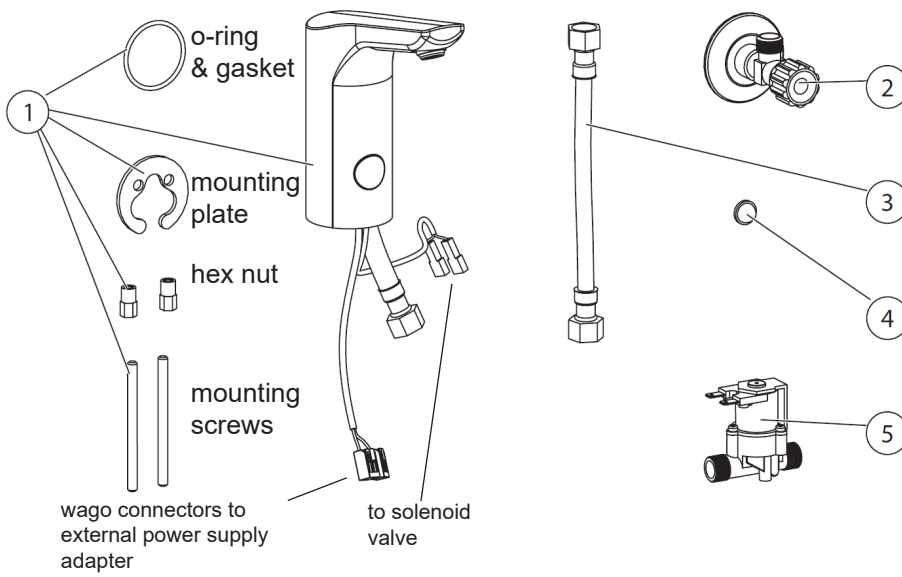

1	Faucet Components
2	Angel Valve
3	Connection hose
4	Filter
5	Solenoid Valve

Standard Functions

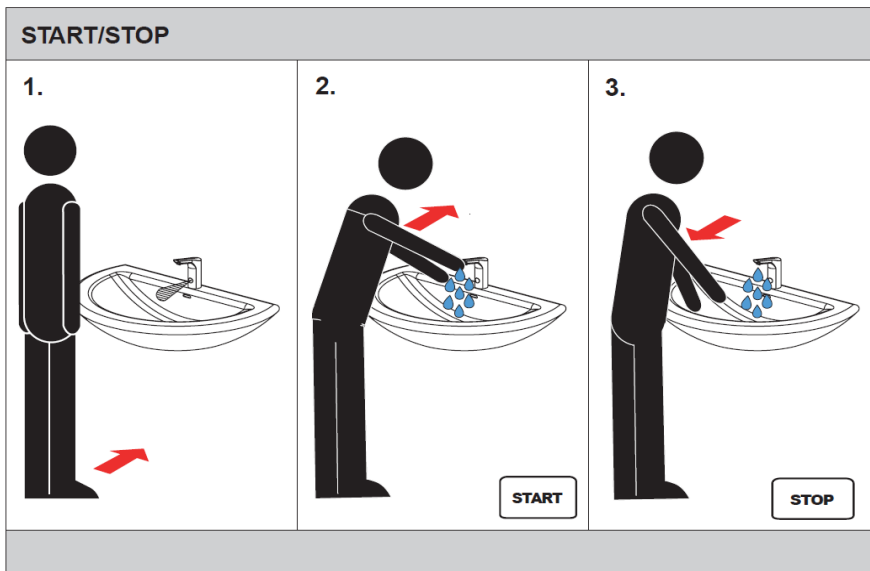

Hands within active range, water flows

Hands removed from active range, water stops

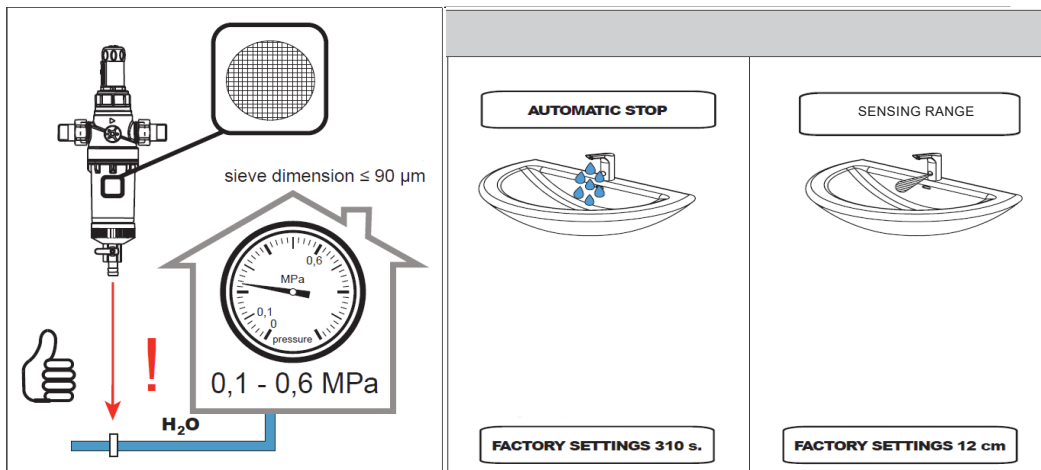

Operating pressure range

After 5 mins of use water will stop

External Power Supply Installation

Input	230V / 50 Hz
Output	24 V DC
IP rating	IP 55
Operating temperature	5°C - 40°C
Rated power	10W

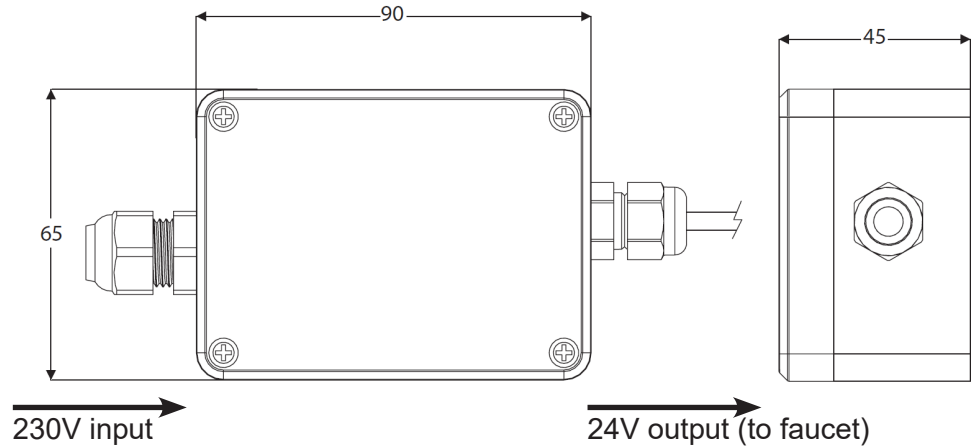

Important

To be installed in accordance with all NZ electrical regulations. It must be carried out by a qualified professional.

Positioning of the mounting box should be 500mm from the floor and consider:

1. Moisture ingress due to plumbing fault
2. Ongoing maintenance and accessibility

The mounting box can be surface mounted or within the service or ceiling cavity.

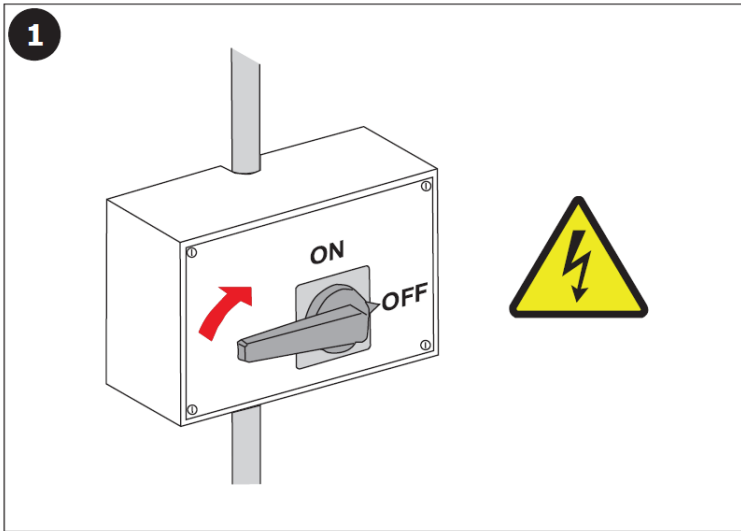

1 Ensure mains power supply is off

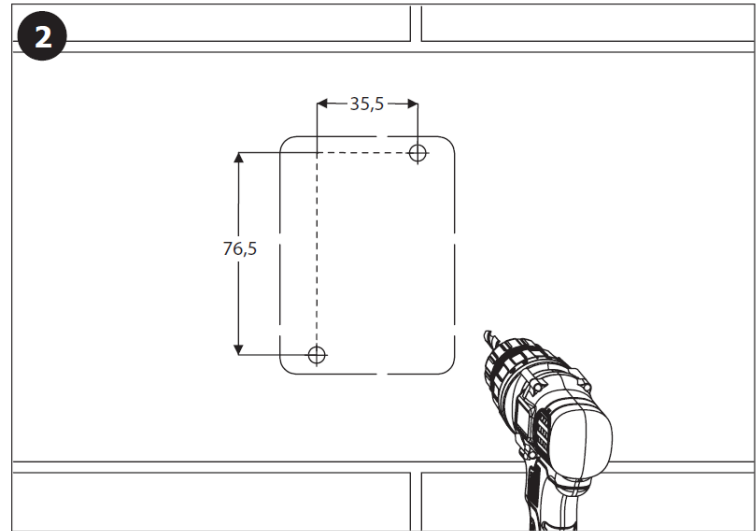

2 Mark mounting point(s) on surface

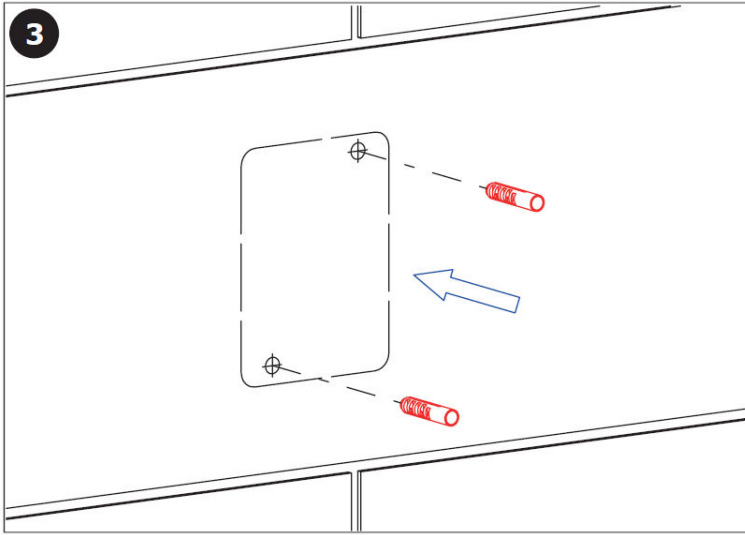

3 Drill and insert appropriate wall anchors if required

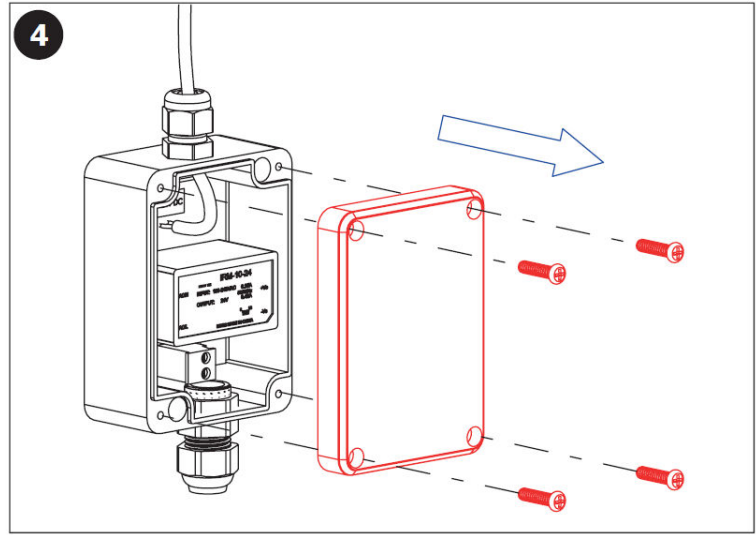

4 Remove cover from mounting box

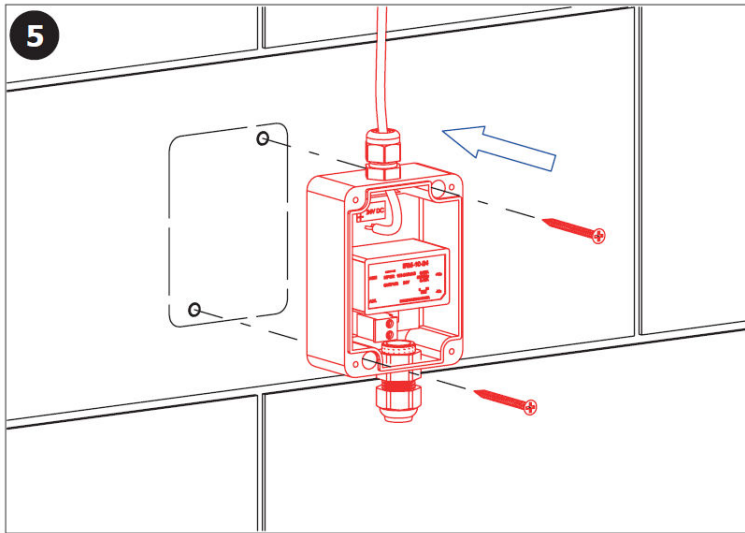

5 Fix mounting box to wall

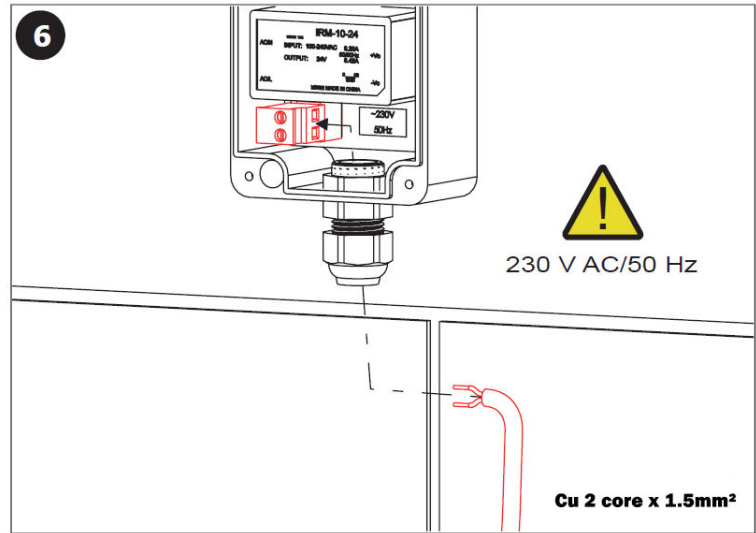

6 Pass mains (230V) power supply into mounting box via grommet and terminate accordingly

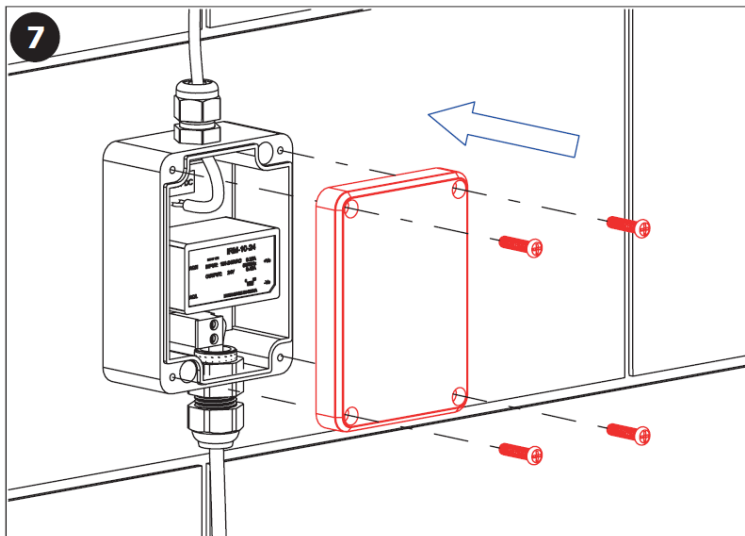

7 Reinstall cover of mounting box and ensure sealed. Tighten grommet to ensure snug around cables

Note: Power supply should be secured via current breaker before the external supply (not included)

Faucet Installation

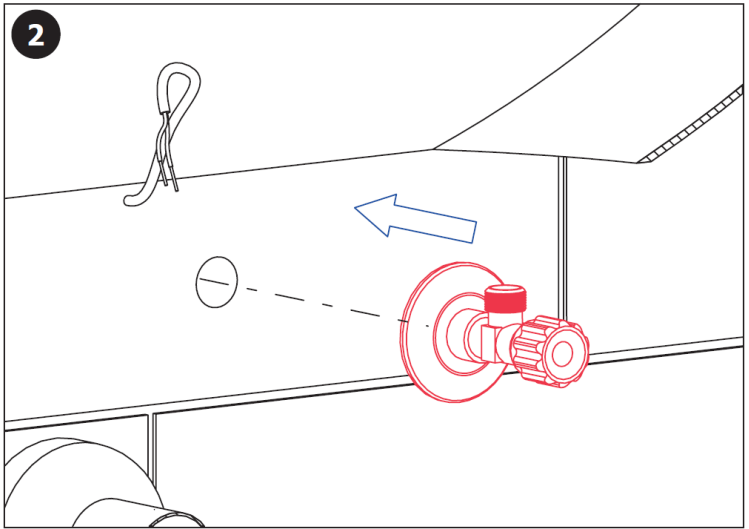
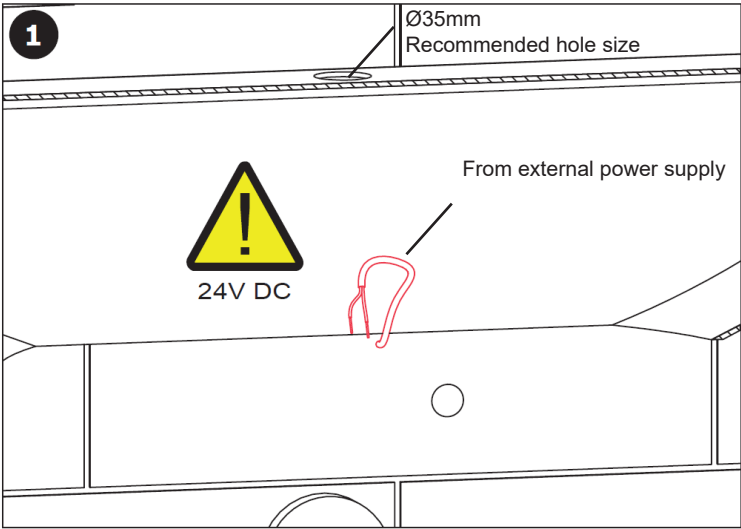

Install 1/2" angle valve

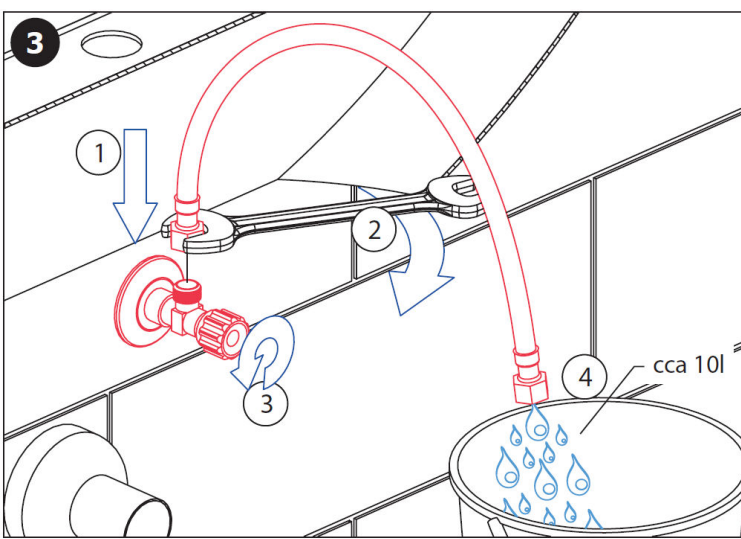

Flush lines thoroughly

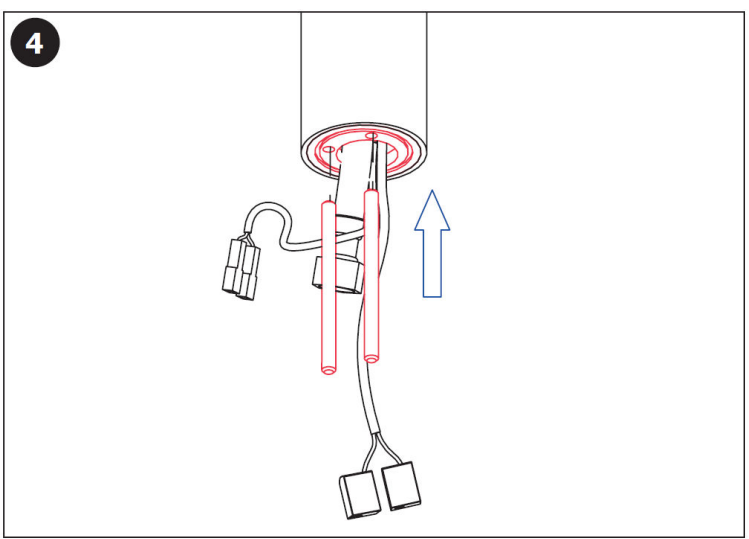

Fit mounting screw, o-ring and rubber gasket

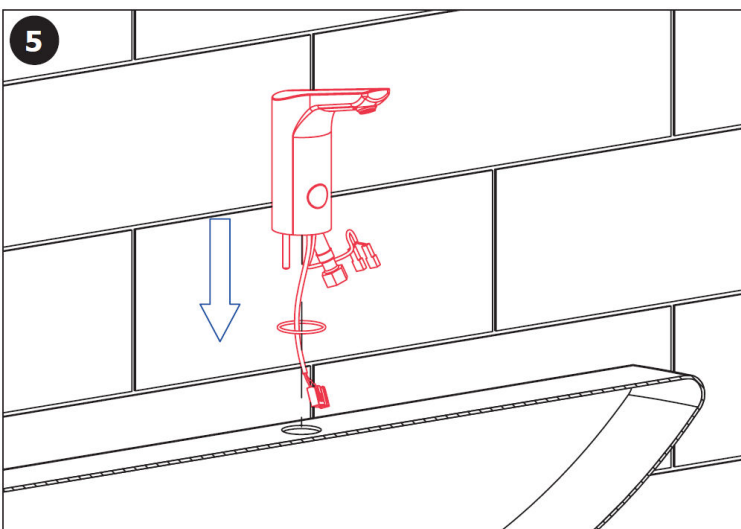

Pass mounting screw, hose and electrical connections through vanity.

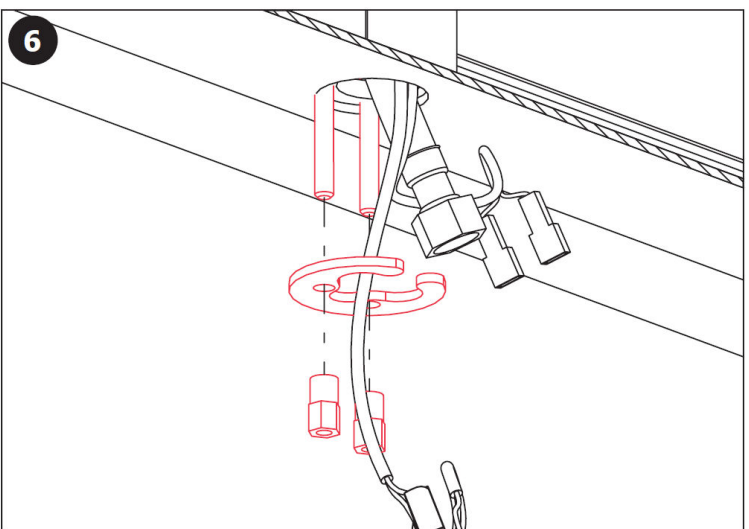

Fit mounting plate and hex nuts

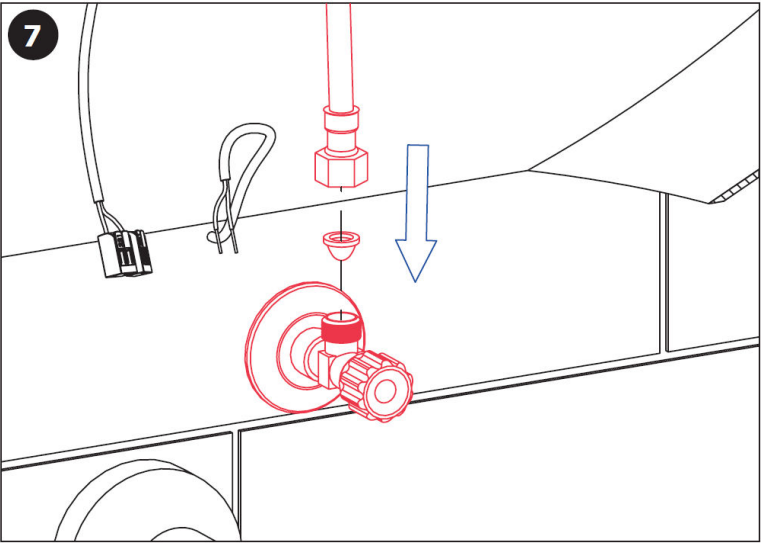

Fit filter into angle valve

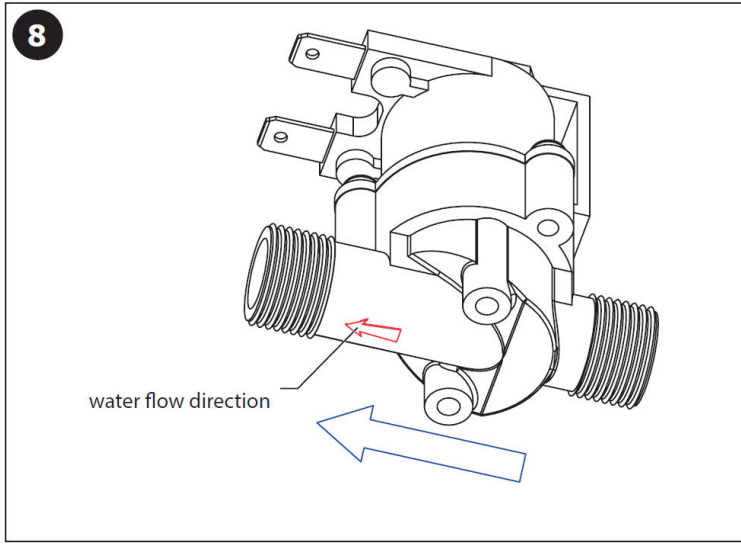

Note arrow on solenoid valve

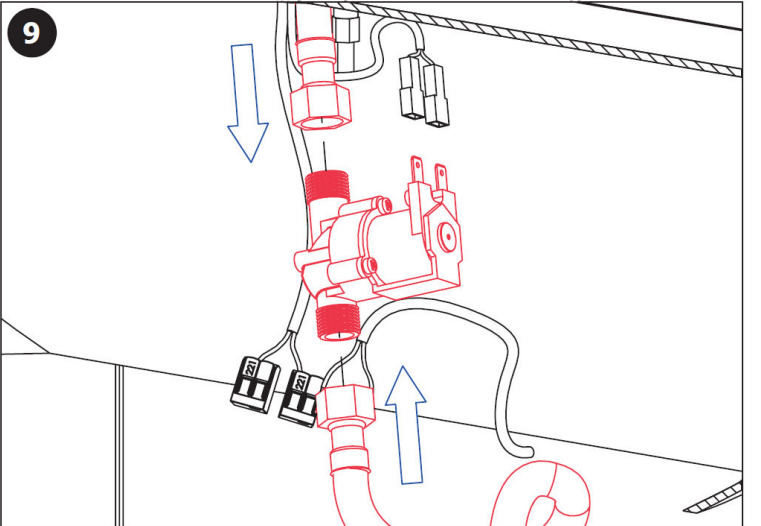

Fit connection hose and solenoid. Note 8

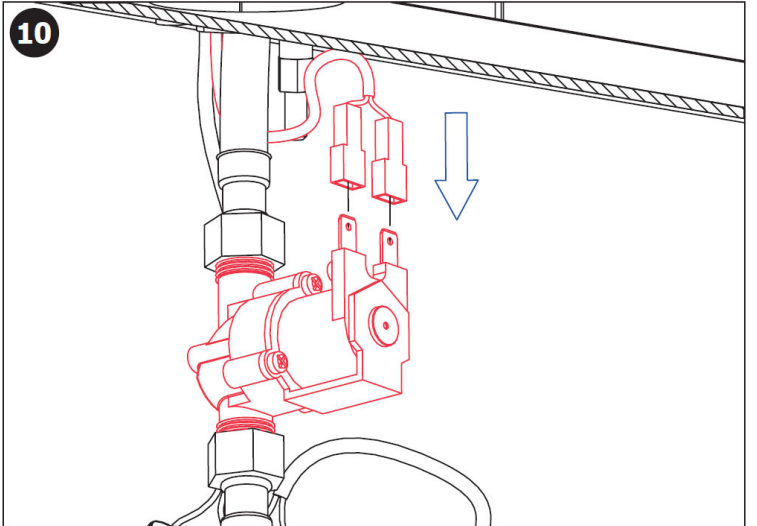

Connect faucet to solenoid valve

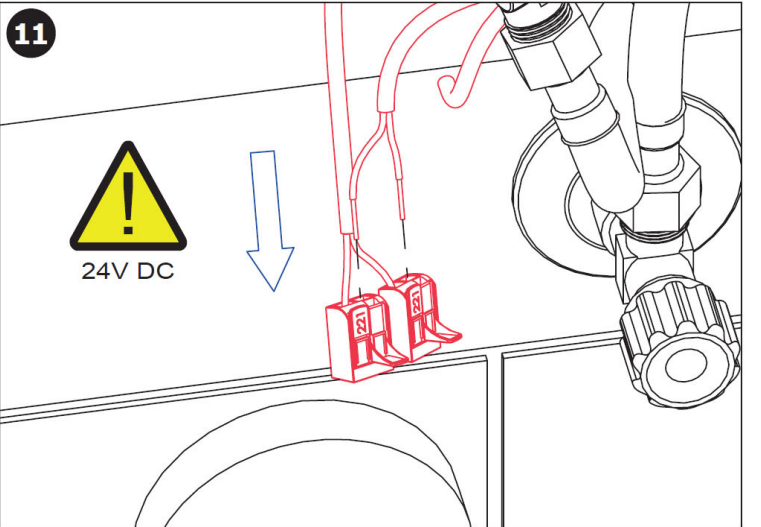

Connect external power (24V outlet) supply to wago connectors on faucet. (Note polarity: brown to brown, white to white)

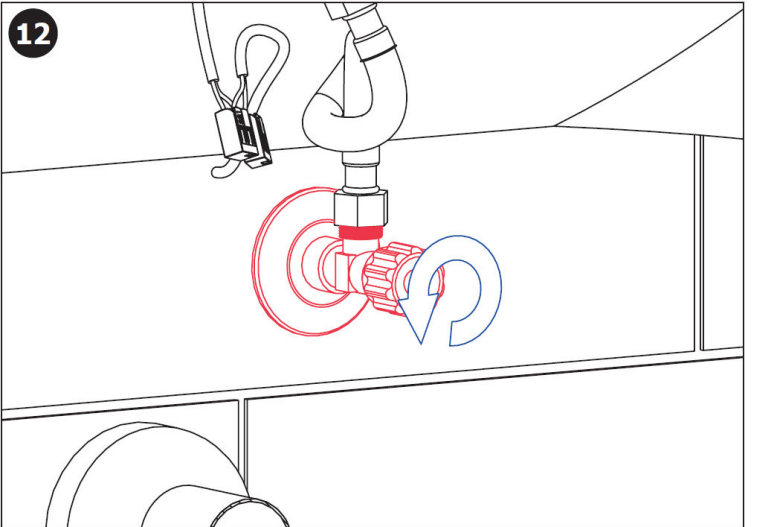

Turn angle valve on and check all connections



Do not come within active range

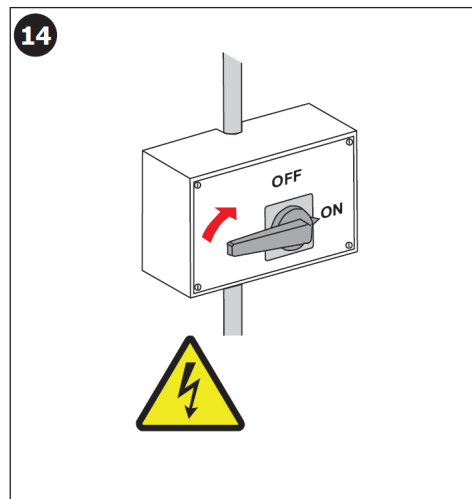

Turn power supply on

It is necessary, for the proper function, to keep the unit under constant voltage (don't connect the power supply unit behind the switch into the light circuit)

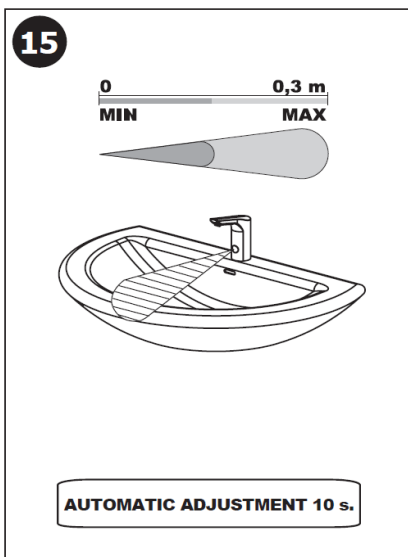



Once power is turned on, faucet will automatically adjust sensing range during first 10 seconds. The LED on sensor will continually flash, do not come in active range during this time.

Important

- Pipework is required to be flushed thoroughly prior to faucet and solenoid installation. Foreign debris may reduce level of flow and in some cases damage the solenoid valve.
- The sensor of the faucet must not be obstructed.
- Avoid positioning reflective objects or surfaces in front of the faucet sensor. This can cause false activation i.e. mirrors opposite faucet. With wall mounted faucets pay particular attention to the distance between the bottom of the basin and the faucet (minimum of 300mm) and the location and material of the basin waste (avoid mounting directly over the waste and/or choose non reflective options).
- All plumbing and electrical installation must be carried out by a qualified person and in accordance with applicable codes and regulations.

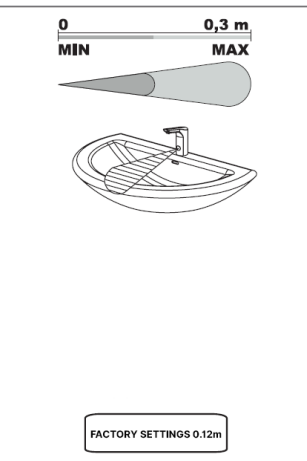
Note: If you require to modify any of the factory settings please request the Sanela remote SLD03.

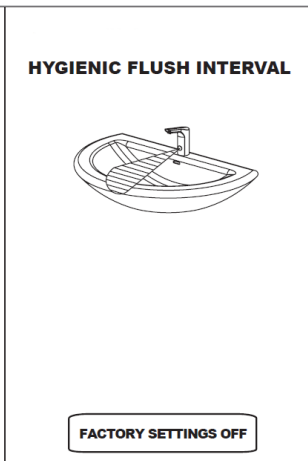
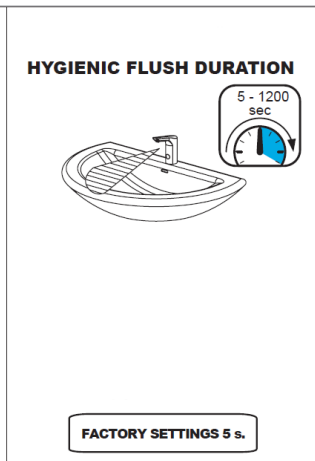
Activation Range	Time Delay	Hygienic Flush	
		<p data-bbox="815 394 1082 416">HYGIENIC FLUSH INTERVAL</p> 	<p data-bbox="1125 394 1391 416">HYGIENIC FLUSH DURATION</p> 
SLD 03: 0,1 - 0,3 m	SLD 03: 0,25 - 7,75 s.	SLD 03: OFF / 6 / 8 / 12 / 24 / 72 / 168 h	

Maintenance

- It is recommended that the solenoid valve and all filters be inspected for foreign debris and cleaned annually (more frequently if necessary)
- Clean faucet regularly using soapy water and a soft cloth or wet sponge
- DO NOT clean faucet with any abrasive material or chlorine/acid based cleaning product. This may damage the filter of the infrared sensor and/or the finishing of the faucet.

Troubleshooting

Symptom	Possible Cause	Corrective Action
No water flow - is LED on sensor flashing red when hands are within active range?	<ul style="list-style-type: none"> a. Water supply b. Water connections c. Filter is clogged d. Faucet to solenoid power connection e. Faulty solenoid 	<ul style="list-style-type: none"> a. Ensure water at source b. Ensure connections c. Clean filter (angle valve and solenoid) d. Reconnect plugs from faucet to solenoid valve e. Replace solenoid
No water flow - LED on sensor NOT flashing when hands are within active range.	<ul style="list-style-type: none"> a. Power supply b. Power connectors to faucet (wago connectors) c. IR sensor damaged d. Faulty IR sensor 	<ul style="list-style-type: none"> a. Ensure power at source b. Check all connections and polarity c. Replace IR sensor filter d. Replace IR sensor
Water doesn't stop flowing	<ul style="list-style-type: none"> a. Dirty IR sensor b. Obstruction in detection zone c. Water drop on sensor eye d. Ghost sensing due to reflection e. Debris in solenoid 	<ul style="list-style-type: none"> a. Clean IR sensor b. Remove obstruction c. Wipe sensor d. Remove reflective surface or reposition e. Clean and/or replace solenoid
Reduced flow rate	<ul style="list-style-type: none"> a. Filter clogged b. Aerator clogged c. Water supply 	<ul style="list-style-type: none"> a. Clean filter b. Clean aerator c. Check pressure / flow at source

Supreme Comprehensive Warranty

Your Supreme sensor tap is fully guaranteed against defective materials and faulty workmanship commencing from the date of sale (according to SPL's records), subject to it being installed and maintained in accordance with the manufacturer's instructions.

SPL (2021) Limited warrants that should any part of the sensor tap fail within the given warranty period (24 months), it will be remedied by SPL. The tap should be returned to SPL (2021) Limited for all warranty claims. The cost of cartage will be payable by the customer.

This warranty excludes:

- Incorrect installation, or installation that does not specifically follow the installation guidelines supplied
- Failure to follow manufacturer's maintenance instructions
- Damage/Failure resulting from:
 - the use of non-authorized parts
 - authorized parts not installed in accordance with the manufacturer's instructions
 - accidental damage, negligent use, misuse, vandalism, neglect
 - damage caused either directly or indirectly by external sources (incorrect power supply, natural disaster, or insect infestation)
- Water ingress caused by property maintenance or flooding
- Negligent cleaning practices (water ingress, harmful chemical etc)

The above includes consequential damage to any other goods, furnishings, or property.

- Normal wear and tear and consumable parts (batteries etc)
- This warranty does not displace any statutory warranty in relation to the dispenser but any liability of SPL (2021) Limited under any statutory warranty will be limited to a replacement or repair of the dispenser or payment of the cost of such replacement or repair at the sole discretion of SPL (2021) Limited

Note:

- Warranty only extends to products purchased and installed in New Zealand.
- Contamination or poor water quality is not covered by product warranty.
- Damage to solenoid caused by inadequate flushing or excess water pressure is not covered by the product warranty.

SPL Limited
PO Box 437, Cambridge 3450
New Zealand

p. +64 7 823 5790
e. office@splwashrooms.co.nz