

Xibu

senseTAP PROFI

C1/C2
L1/L2
H1/H2

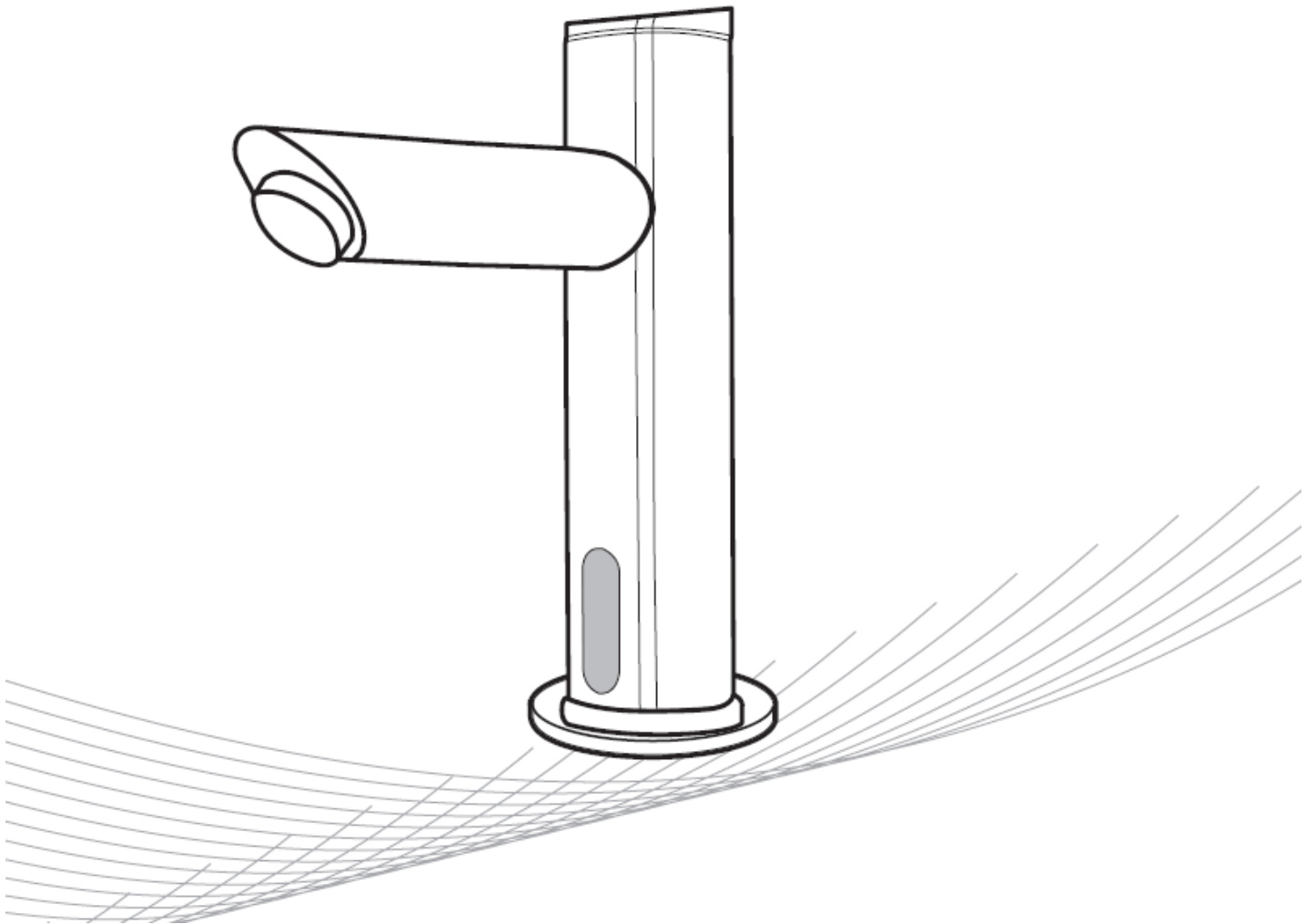

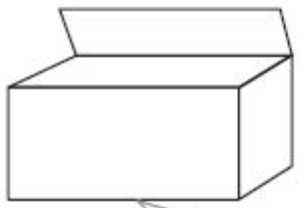

chrom (Typ 1100 B/N, 1110 B/N, 1120 B/N)
matt (Typ 1200 B/N, 1210 B/N, 1220 B/N)

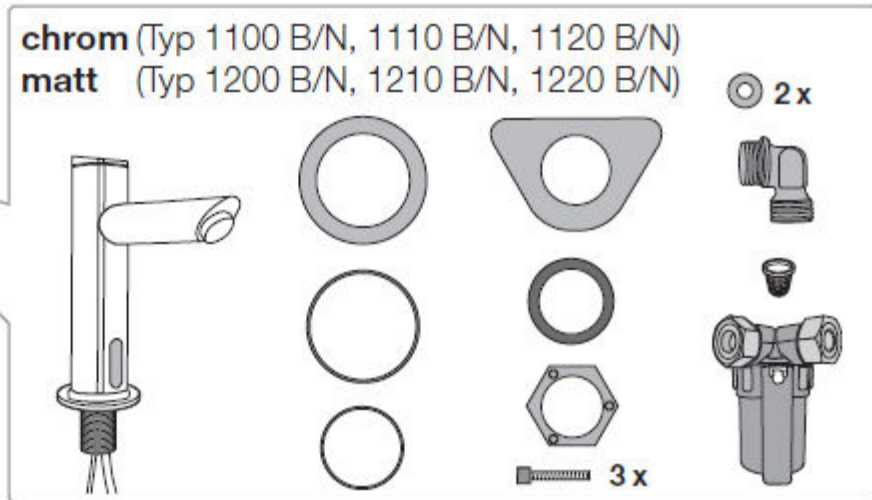

inox (Typ 1400 B/N, 1410 B/N, 1420 B/N)

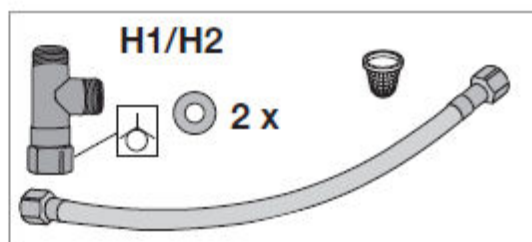
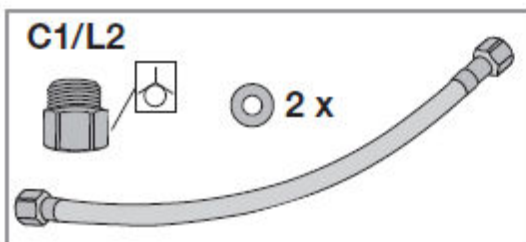
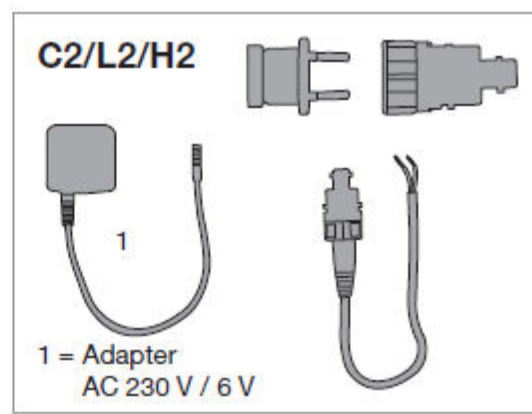
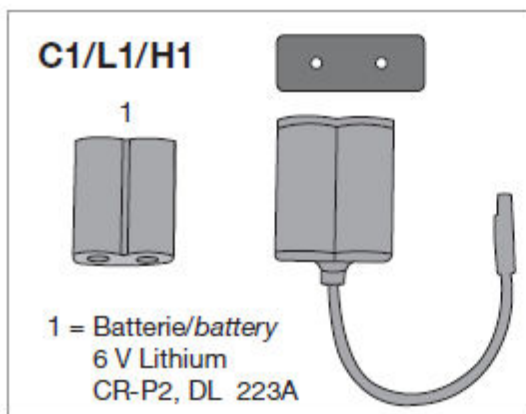
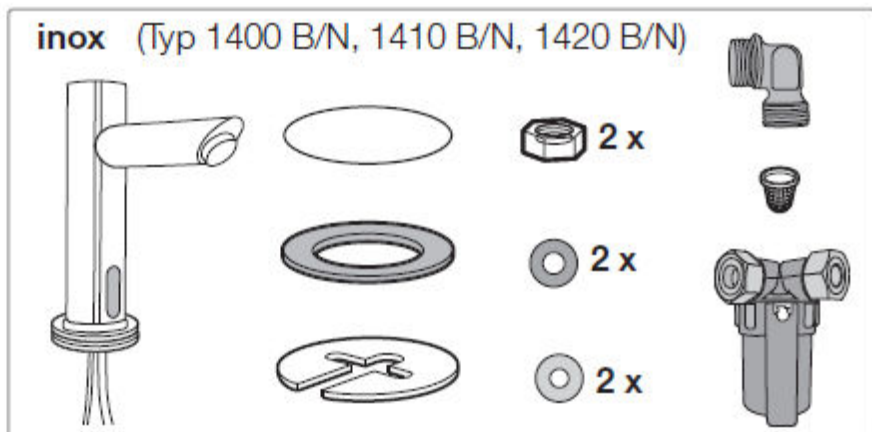

1.

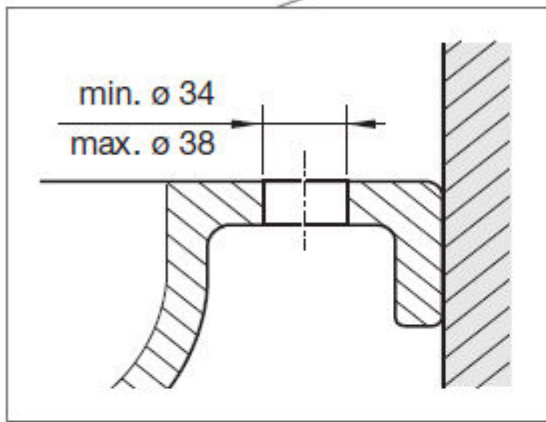
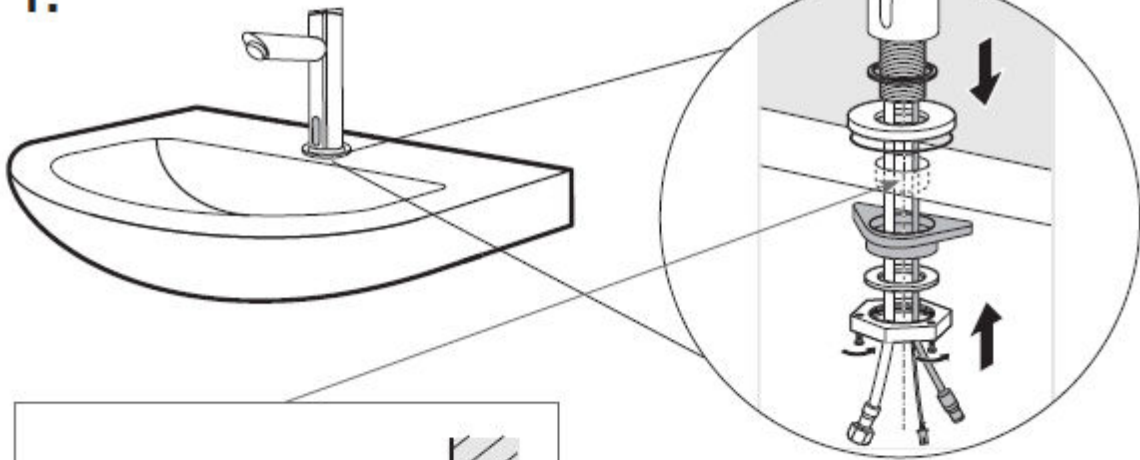

2.

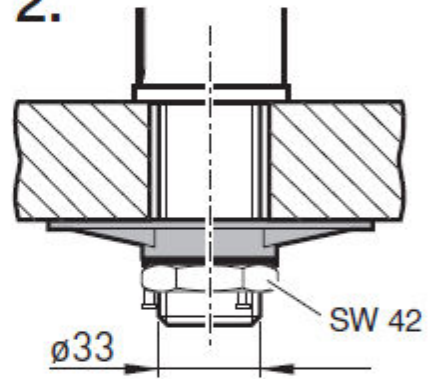

inox

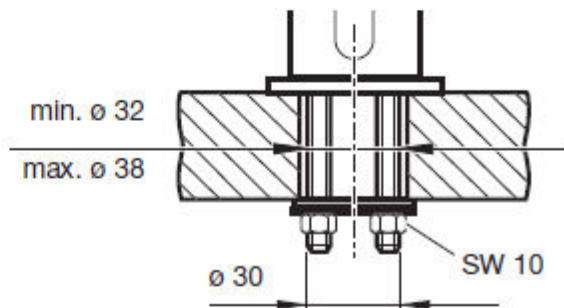
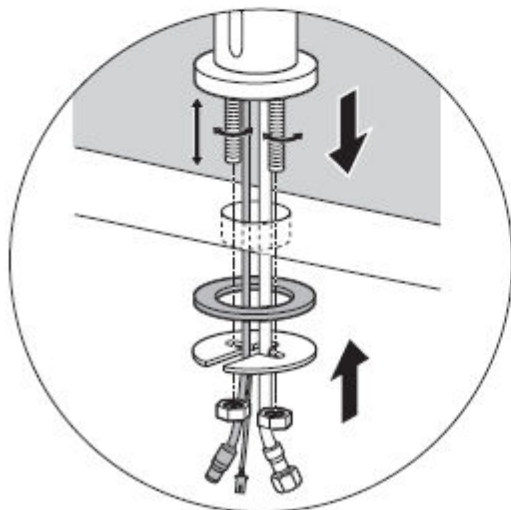

C1/C2

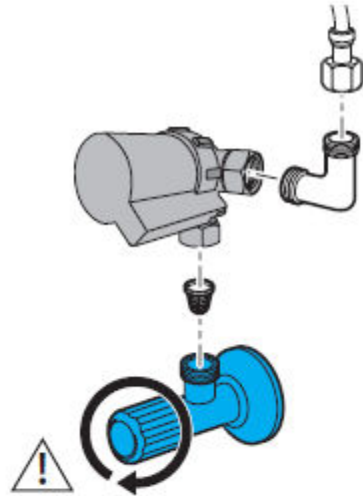
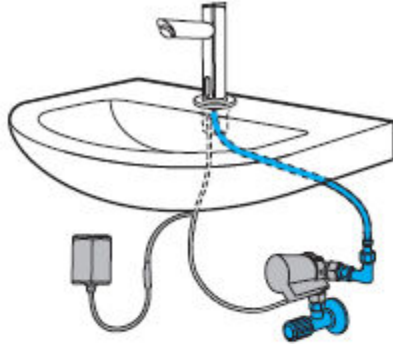

L1/L2

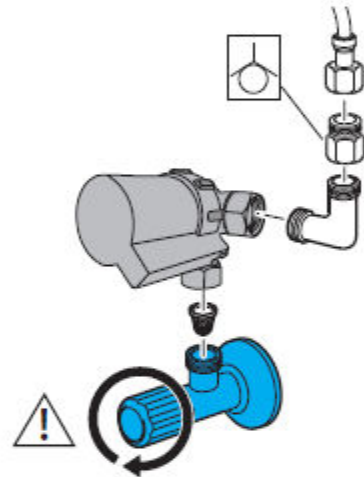
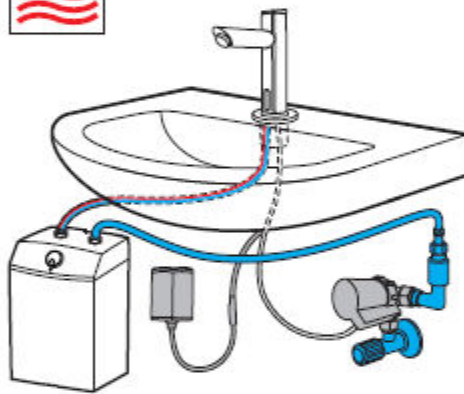

H1/H2

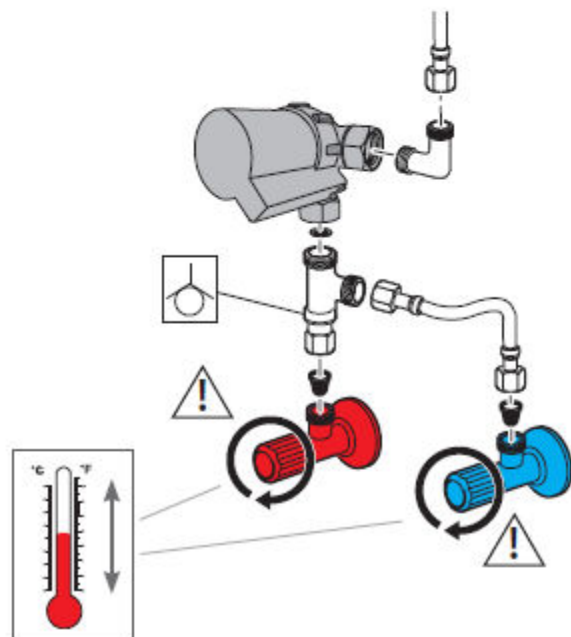
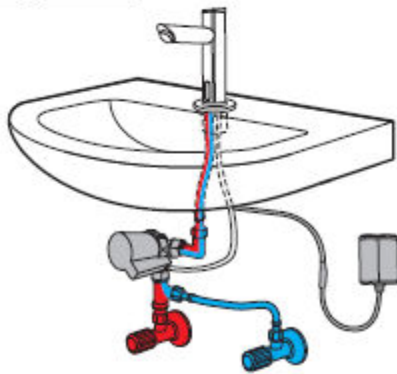

C1/L1/H1

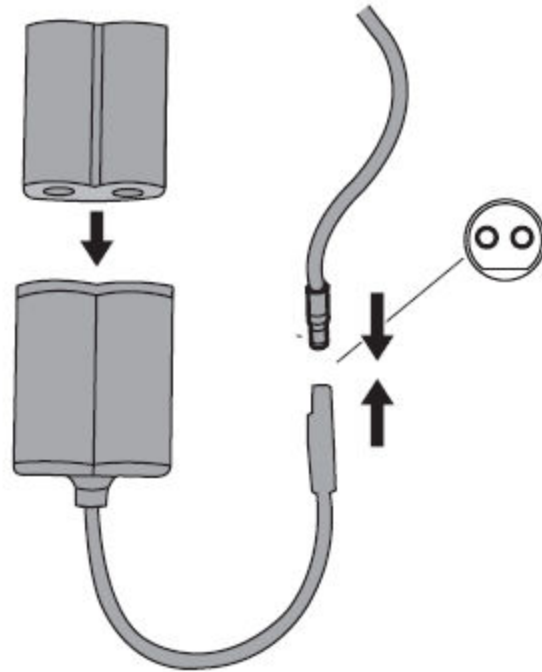

C2/L2/H2

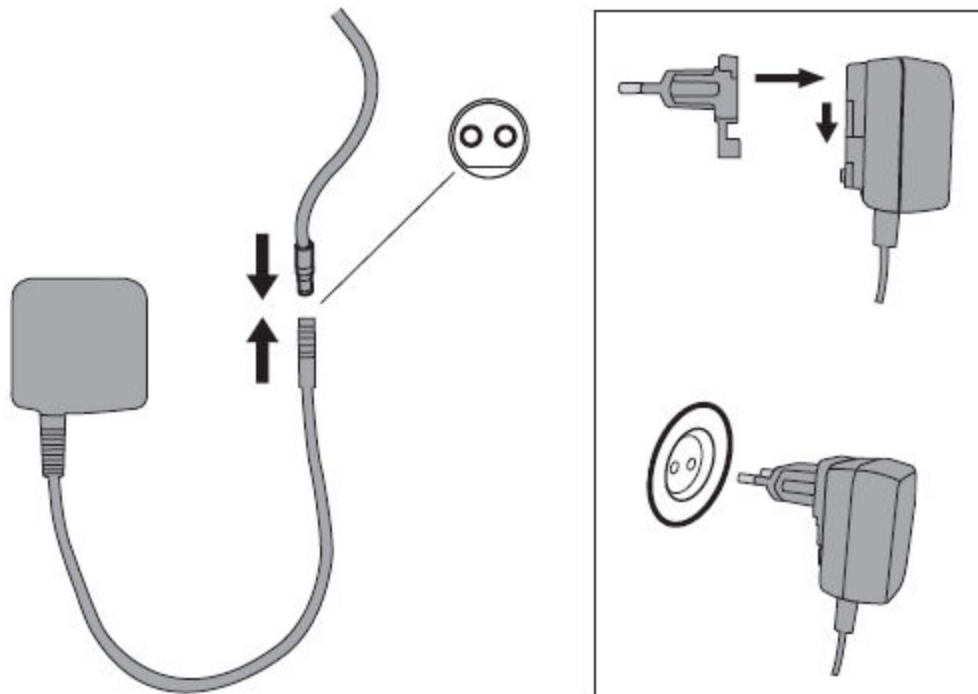

Operation:

Automatic range adjustment

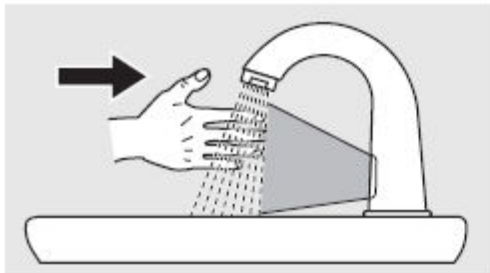
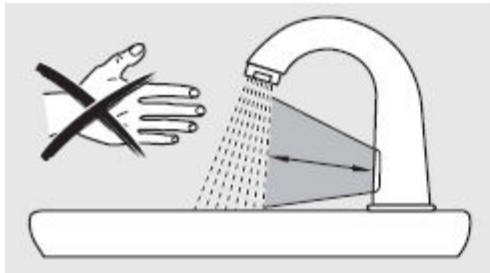

! Before electrical connection or insertion of batteries pay attention that the corner valves are open.

Do not hold your hands in front of the armature until the adjustment of the sensor range!

- 10-15 sec. after electronic operation water will run and the range of the sensor will adjust automatically to the distance of the water jet.

Function test

- ➔ Hold your hands towards the area of the water jet/drain.
- Water is running: OK
- Water is not running: see chart below.

Important notice:

- Follow standards, guidelines and regulations of the country and the local water works!
- Installation only in frost-proof rooms!
- Installation only by skilled expert staff.

| Error | Reason | Solution |
|------------------------------|---|---|
| Water is not running | <ul style="list-style-type: none"> ○ Corner valves are closed ○ Main water tap closed ○ Electrical supply disconnected ○ Sensor is not working ○ Magnet valve broken | <ul style="list-style-type: none"> ➔ Open corner valves ➔ Open main water tap ➔ Activate electrical supply ➔ Contact/call service ➔ Unfasten magnet valve and blow out (clean) |
| Water is only running low | <ul style="list-style-type: none"> ○ Filter screens contaminated ○ Aerator contaminated/calcified | <ul style="list-style-type: none"> ➔ Clean filter screens ➔ Clean/decalcify aerator |
| Water is running permanently | <ul style="list-style-type: none"> ○ Magnet valve broken | <ul style="list-style-type: none"> ➔ Close corner valves and contact/call service ➔ Unfasten magnet valve and blow out (clean) |
| LED display (sensor) flashes | <ul style="list-style-type: none"> ○ Empty battery | <ul style="list-style-type: none"> ➔ Close corner valves and change battery |