

# SUPREME

FOAM SOAP



Installation  
& maintenance  
instructions.



# Operating Instructions and Parts Manual

Please read carefully before attempting to assemble, install, operate or maintain the product described. Protect yourself and others by observing all safety information. Failure to comply with instructions could result in personal injury and/or property damage. Retain instructions for future reference.

## Supreme Foam Soap dispenser

### Description:

The Supreme Foam Soap dispenser sensor activated. Soap tank is easy to fill with any foam-type soap. Wall mounted and battery operated for touch-free use.

## Specifications

Operation	Automatic non-touch
Finish / Material	ABS + Aluminium alloy with anodised finish
Soap Type	Foam soap
Capacity	1000ml (refillable) - up to 2500 portions per litre based on 1 drop
Portion Control	0.4 - 0.8 ml per dose
Power	Requires 4 x C size batteries
Dimensions	280H x 140W x 120D mm
Weight	1kg (net)
Fixing	Screws, wall anchors and 3M strips included
Warranty	12 months (excludes batteries)

## Planning

We suggest that one soap dispenser be installed for every hand basin.

Beware of reflection from bright surfaces that may cause false activation.

Detection range is 100mm.

## Recommended Mounting Heights

From basin to bottom of soap dispenser:

No less than 400mm

# Installation Instructions

1. Check the surface of wall is smooth and clean.
2. Note the distance between dispenser & counter top should not be less than 400mm, see Fig.1
3. Use key supplied to unlock and open the soap dispenser outer cover, see Fig.2.
4. Use the soap dispenser to mark the location for the top key hole fixing (1) in Fig.3.
5. Using mounting screws, loosely fit dispenser into key hole fixing (1)
6. Mark location of mounting holes (2 & 3). Remove dispenser and drill holes. (2 & 3) see Fig.4.
7. Mount dispenser and tighten screws, see Fig.5.
8. Remove the battery cartridge cover, load 4 pcs alkaline C size 1.5V batteries and close battery cover, see Fig 6.

## Option - 3M Strip installation

1. Clean installation surface with isopropyl alcohol.
2. Peel paper off of adhesive tape located on back of dispenser.
3. Press dispenser firmly onto mounting surface by applying pressure to the inside of backplate for 30 seconds. Do not load refill for at least 10 hours.
4. Remove the battery cartridge cover, load 4 pcs alkaline C size 1.5V batteries and close battery cover, see Fig 6.

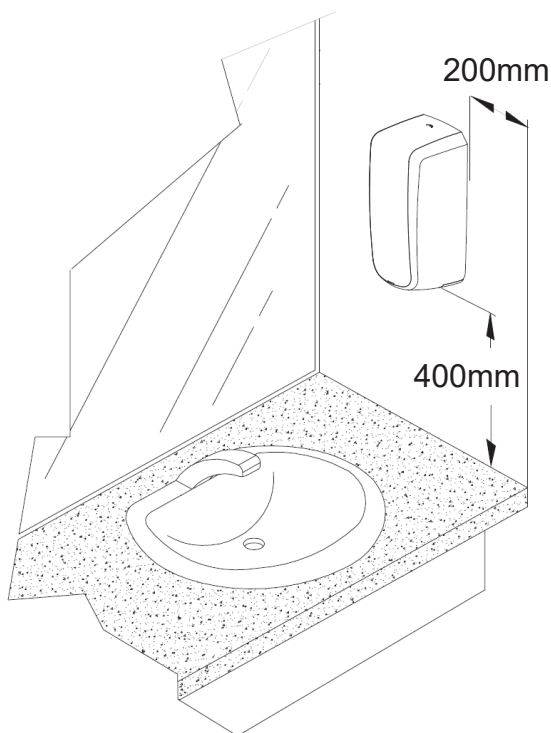

Fig. 1

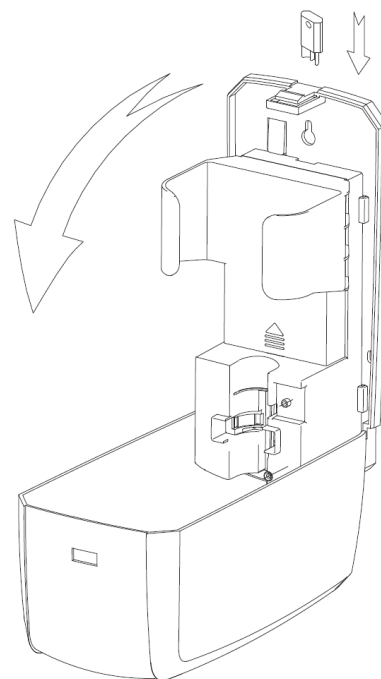

Fig. 2

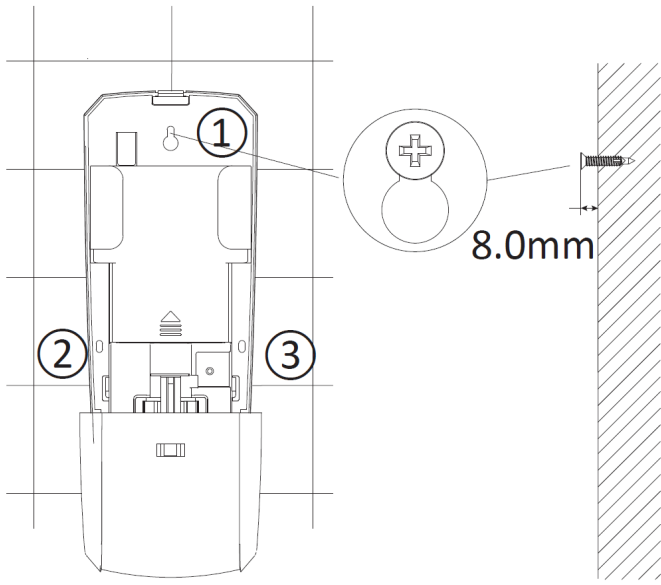

Fig. 3

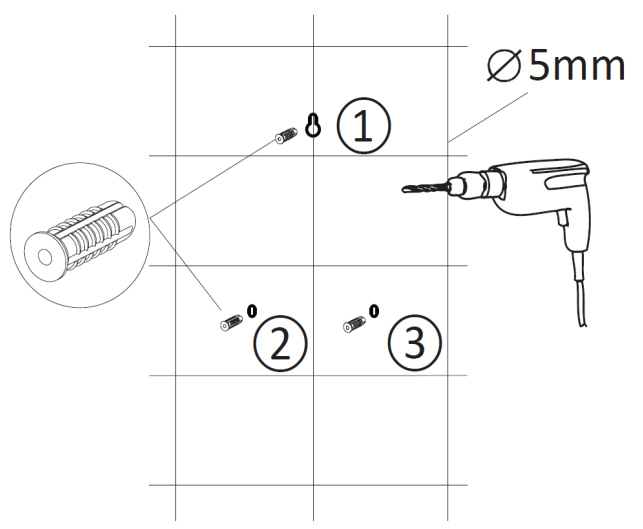

Fig. 4

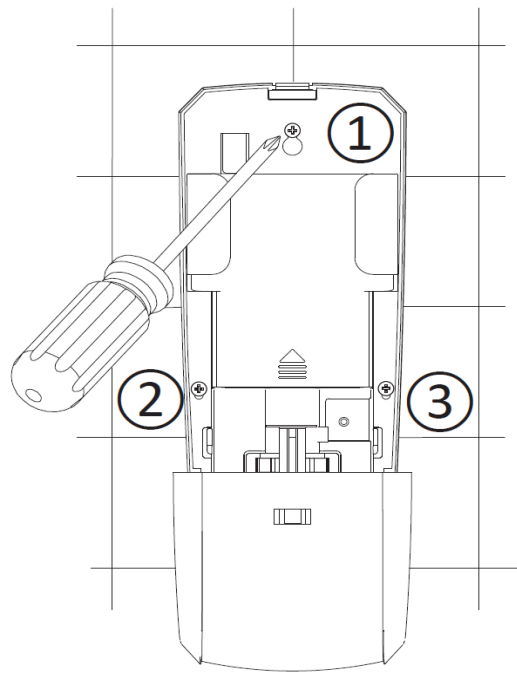

Fig. 5

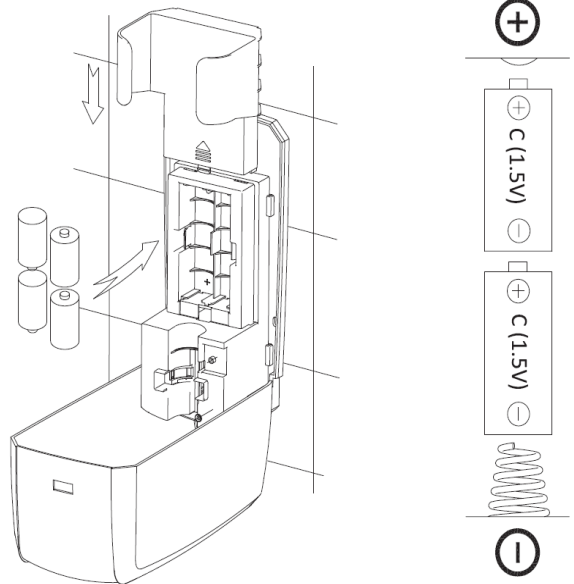

Fig. 6

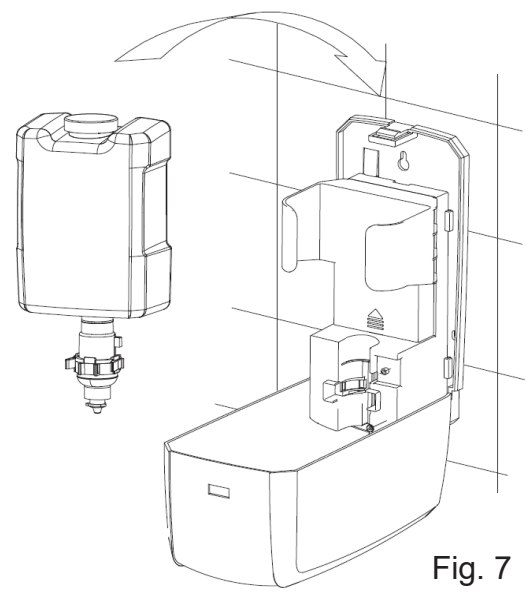
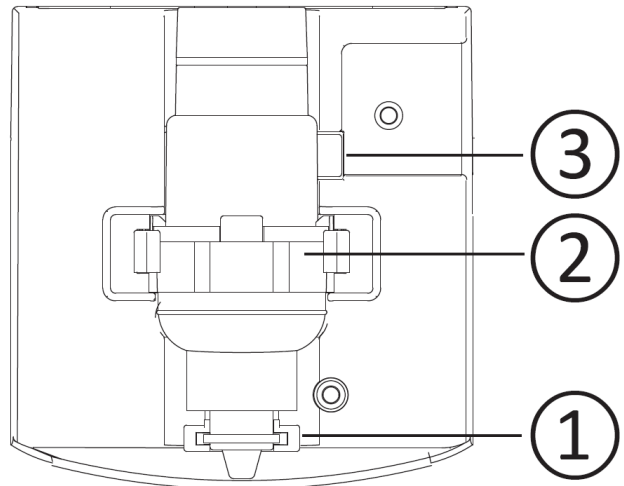

Fig. 7

## Installing Soap Tank

The nozzle of the pump must be fixed into the groove of the push rod. (1)  
The pump should be fitted into the groove of the control box. (2) & (3)

Soap is not included.



## Portion Control

Dispenser comes factory set to dispense 1 portion of soap per activation.

This can be reset to 2 portions per activation by pressing button 3 times in 2 seconds.

To reset to factory settings, remove batteries and replace.

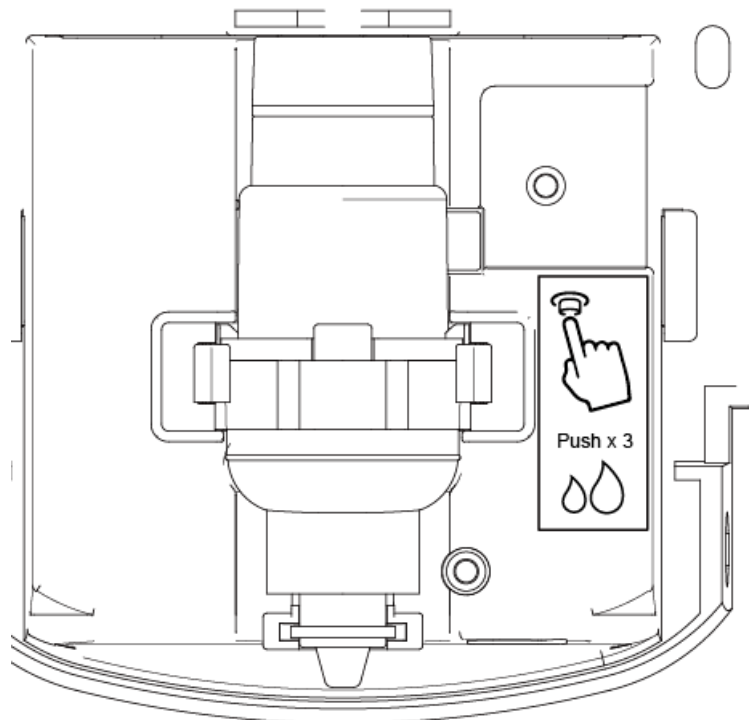

## Operation

1. Close dispenser cover to liven electronics.
2. Place hand below dispenser to activate. Repeat this a couple of times to purge pump.
3. Low battery is indicated via LED flashing every 3 seconds.

Note:

- Do not mix old and fresh batteries.
- Refill soap tank with foam type soap only.

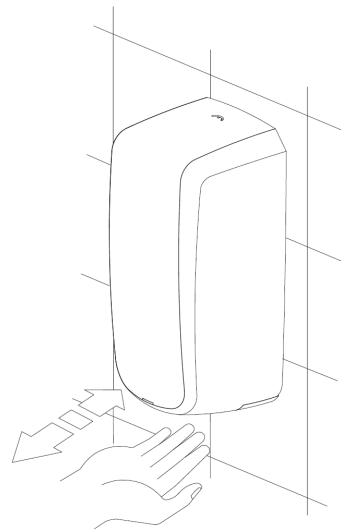

# Maintenance

1. Beware of reflection from bright surfaces that may cause false activation.
2. Clean the appliance daily with a soft cloth and non-abrasive, non-caustic fluid.
3. Non operation can occur if soap tank is not replaced properly.

# Troubleshooting

Symptom	Corrective Action
Dispenser is not activating and no LED is showing	Check the cover is closed correctly
	Check batteries are inserted correctly
	Check for dirt on the sensor
LED light flashing	Replace batteries
LED flashing after soap tank has been refilled	Check soap tank has been installed correctly in 3 locking positions

# Supreme Comprehensive Warranty

Your Supreme soap dispenser is fully guaranteed against defective materials and faulty workmanship commencing from the date of sale (according to SPL's records), subject to it being installed and maintained in accordance with the manufacturer's instructions.

SPL (2021) Limited warrants that should any part of the soap dispenser fail within the given warranty period (12 months), it will be remedied by SPL. The dispenser should be returned to SPL (2021) Limited for all warranty claims. The cost of cartage will be payable by the customer.

This warranty excludes:

- Incorrect installation, or installation that does not specifically follow the installation guidelines supplied
- Failure to follow manufacturer's maintenance instructions
- Damage/Failure resulting from:
  - the use of non-authorized parts
  - authorized parts not installed in accordance with the manufacturer's instructions
  - accidental damage, negligent use, misuse, vandalism, neglect
  - damage caused either directly or indirectly by external sources (incorrect power supply, natural disaster, or insect infestation)
- Water ingress caused by property maintenance or flooding
- Negligent cleaning practices (water ingress, harmful chemical etc)

*The above includes consequential damage to any other goods, furnishings, or property.*

- Normal wear and tear and consumable parts (batteries etc)
- This warranty does not displace any statutory warranty in relation to the dispenser but any liability of SPL (2021) Limited under any statutory warranty will be limited to a replacement or repair of the dispenser or payment of the cost of such replacement or repair at the sole discretion of SPL (2021) Limited

Note: Our Warranty only extends to products purchased and installed in New Zealand.

SPL Limited  
PO Box 437, Cambridge 3450  
New Zealand

p. +64 7 823 5790  
e. [office@splwashrooms.co.nz](mailto:office@splwashrooms.co.nz)