

DELTA

SENSOR TAPS



Installation
& maintenance
instructions.

Operating Instructions and Parts Manual

Please read carefully before attempting to assemble, install, operate or maintain the product described. Protect yourself and others by observing all safety information. Failure to comply with instructions could result in personal injury and/or property damage. Retain instructions for future reference.

Delta Sensor Taps

The Delta Sensor tapware range are motion sensor activated for easy touch-free use. Basin mounted with battery or mains power options.

Specifications

Facet Body / Finish	Brass / Chrome
Power	DC 6V (4 x AA) Battery or 240V AC
Water Pressure	0.5-6 bar (7-85 PSI)
Water Temperature	5-55° C (optional extra thermostatic mixing valve)
<u>Dimensions DELTA PLUS</u>	
Faucet	144H x 172D x 64W mm
Control Box	110H x 110W x 80D mm
Diameter of inlet /outlet	DN15, G1/2"
<u>Dimensions DELTA</u>	
Faucet	122H x 140D x 68W mm
Control Box	110H x 110W x 80D mm
Diameter of inlet /outlet	DN15, G1/2"
Warranty	12 months excludes battery

Planning

We suggest that one sensor tap be installed for every hand basin.

Beware of reflection surfaces that may cause false activation.

When installing 240V version please consult your electrician.

Product Features

Low power usage: 4 x AA batteries average 2 yrs based on 300 cycles per day

Time out protection: 60 seconds, reset 10 seconds after obstruction is removed

Simple maintenance: Built in water strainer

Low power warning: Flashing LED on sensor (battery version)

Single hole basin: Hole diameter 30-32mm

Typical Installation

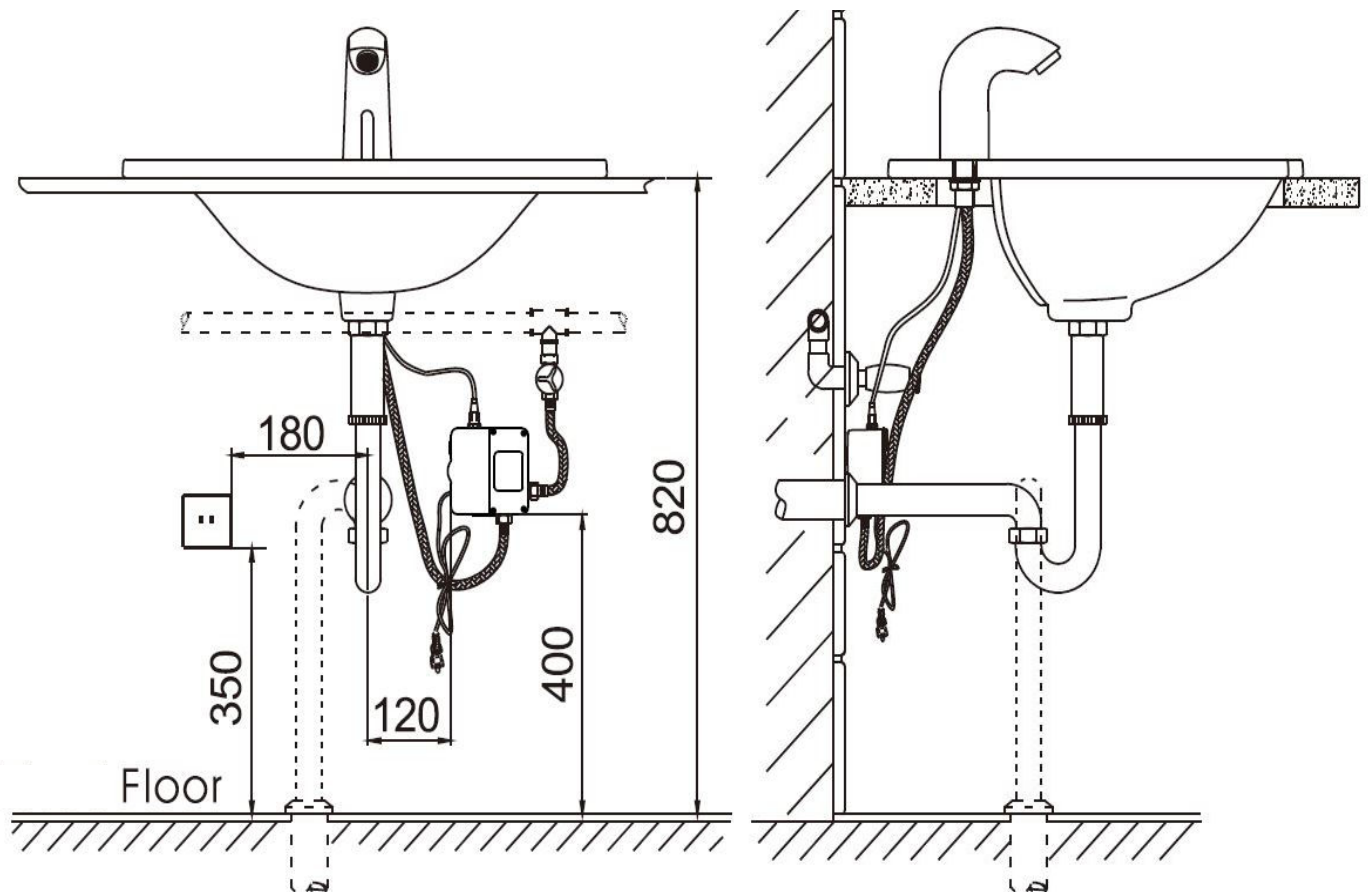

Installation Instructions

1. Fit braided outlet pipe into faucet body then draw this and the sensor flex through the center hole in the basin.
2. Use the fitted washer and fixing nut to fasten the faucet body.
3. Drill two holes in the wall in relation to the holes in the control box mounting bracket. Insert the plastic expansion plugs into the holes and fix the bracket to the wall using the self-tapping screws.
4. Mount the control box onto the bracket and fasten the screws.
5. Insert the sensor plug into the sensor socket of the control box. Fasten the fixing nut.
6. Mount the other end of the braided outlet pipe into the outlet on the control box.
7. Connect the control box to the main water supply pipe with a braided pipe to the inlet on the control box.

Installation of control box

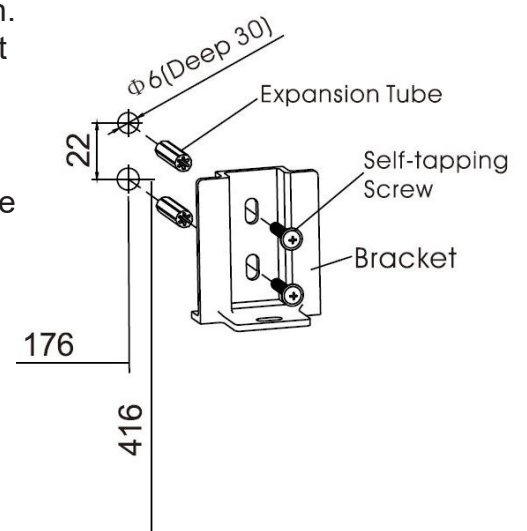

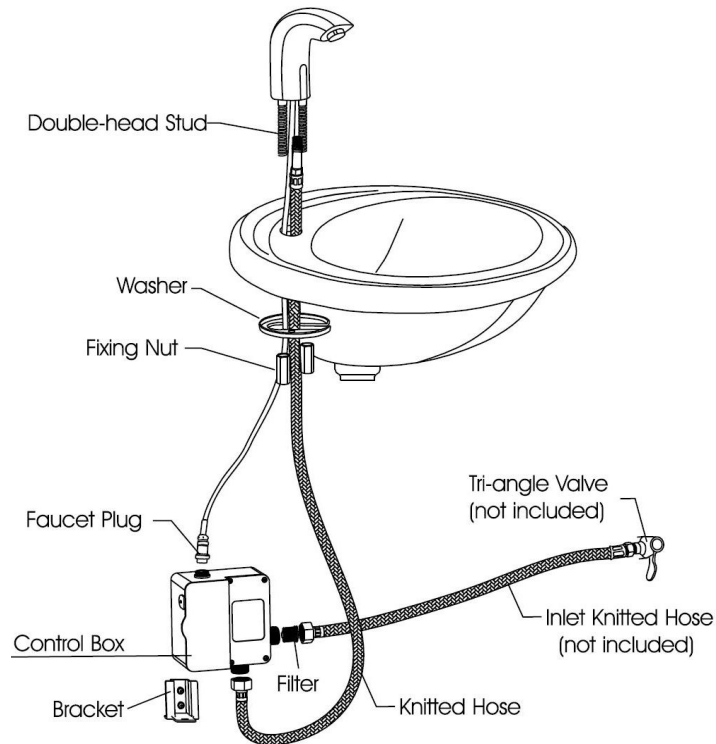

Installation for DC (battery)

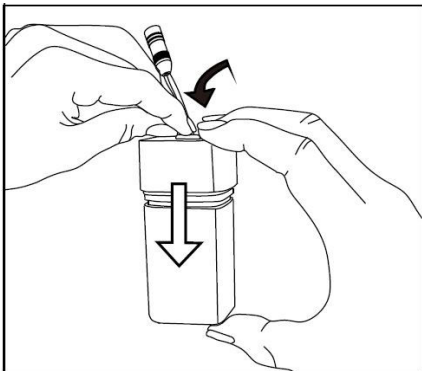
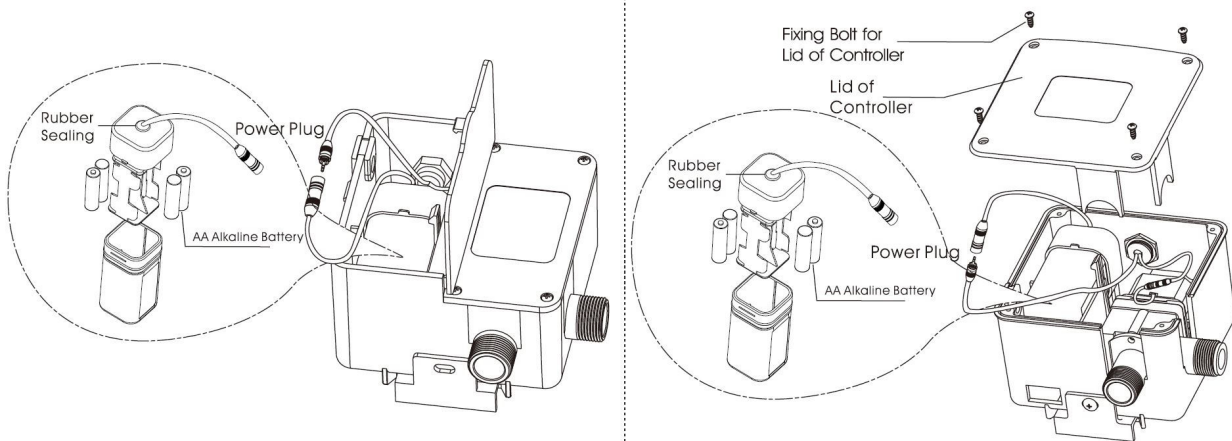

1. Open the control box and take out the battery box.
2. Insert 4 x AA batteries and close. If the box is difficult to close, squeeze the rubber sides to remove air.
3. Place the battery box back into the control box.
4. Connect the battery box and solenoid valve and do up the wires.
5. Close the control box.

Maintenance

Do not use corrosive or abrasive compounds to clean the faucet or detection lens.

Cleaning Filter

Clean the filter after the first month of use, followed by a clean every six months. A reduced flow rate may also be a sign of a dirty filter.

1. Close the water supply.
2. Unscrew the nut at the end of the inlet pipe and take out the filter.
3. Clean the filter with water and remount, then refasten the nut.

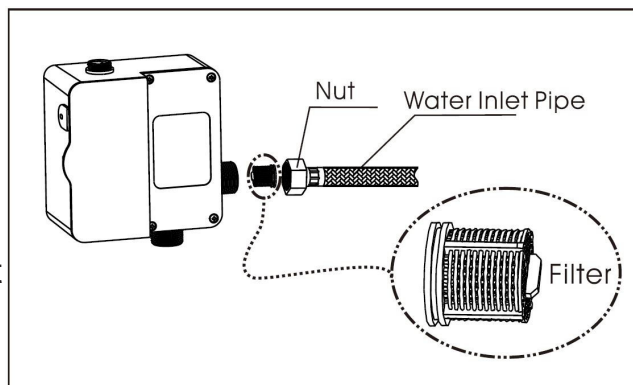

Solenoid Valve Cleaning

Caution: Do not twist or cause tension on the spring when cleaning, this may result in the solenoid working abnormally.

1. Unscrew the nut of water inlet and outlet.
2. Take out the solenoid valve. Unscrew 4 bolts and take out the steel core and steel core spring.
3. Clean it, then replace.

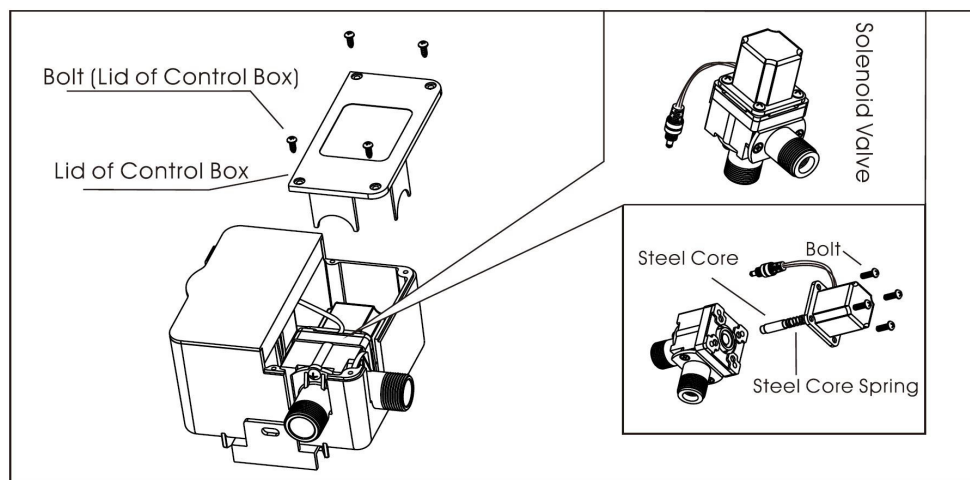

Troubleshooting

Symptom	Possible Cause	Corrective Action
No water flow	Batteries are flat	Replace batteries
	Dirt on sensor eye	Clean sensor
	Water stopped	Reconnect water
	Filter is dirty	Clean filter
	Continuous washing for over 1 minute - timed out	Reuse after 10 seconds
Water doesn't stop flowing	Dirt on sensor eye	Clean sensor
	Obstruction in detection zone	Remove obstruction
	Water drops on sensor eye	Clean sensor
Reduced flow rate	Filter dirty	Clean filter

Checking Power

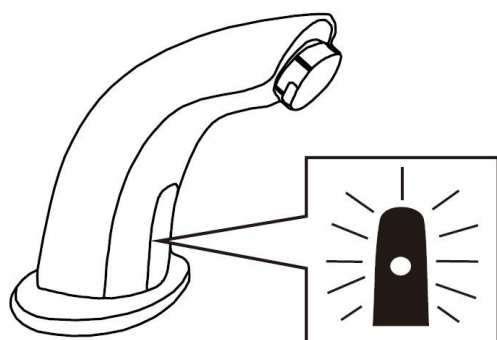

When the indicator light flashes every 2-3 seconds the batteries are running low and will need replacing.

Supreme Comprehensive Warranty

Your Supreme sensor tap is fully guaranteed against defective materials and faulty workmanship commencing from the date of sale (according to SPL's records), subject to it being installed and maintained in accordance with the manufacturer's instructions.

SPL (2021) Limited warrants that should any part of the sensor tap fail within the given warranty period (12 months), it will be remedied by SPL. The tap should be returned to SPL (2021) Limited for all warranty claims. The cost of cartage will be payable by the customer.

This warranty excludes:

- Incorrect installation, or installation that does not specifically follow the installation guidelines supplied
- Failure to follow manufacturer's maintenance instructions
- Damage/Failure resulting from:
 - the use of non-authorized parts
 - authorized parts not installed in accordance with the manufacturer's instructions
 - accidental damage, negligent use, misuse, vandalism, neglect
 - damage caused either directly or indirectly by external sources (incorrect power supply, natural disaster, or insect infestation)
- Water ingress caused by property maintenance or flooding
- Negligent cleaning practices (water ingress, harmful chemical etc)

The above includes consequential damage to any other goods, furnishings, or property.

- Normal wear and tear and consumable parts (batteries etc)
- This warranty does not displace any statutory warranty in relation to the dispenser but any liability of SPL (2021) Limited under any statutory warranty will be limited to a replacement or repair of the dispenser or payment of the cost of such replacement or repair at the sole discretion of SPL (2021) Limited

Note: Our Warranty only extends to products purchased and installed in New Zealand.

SPL Limited
PO Box 437, Cambridge 3450
New Zealand

p. +64 7 823 5790
e. office@splwashrooms.co.nz