

# SUPREME

BABY

STAINLESS STEEL SURFACE MOUNTED



Installation  
& maintenance  
instructions.

**SPL**

## General Safety Information

- This product is intended for children up to a maximum weight of 20kgs.
- DO NOT leave your child unattended while using a baby change table.
- DO NOT add a changing pad to this product.
- Always use safety belt.
- Forbid children from hanging from the unit to avoid risk of falling.
- Be aware of the risk of open fires and other sources of strong heat, such as electric heaters, gas fires, etc in the near vicinity of the baby change table.
- Adding excessive weight to the unit that exceeds the total weight limit of 20kgs may cause a hazardous, unstable condition to occur.
- Do not use the changing table when any part is broken, torn or missing.

## Warning

- The baby change table is no stronger than the anchors or wall to which they are attached and therefore **MUST** be firmly secured in order to support the weight they are intended to support. Contact a builder or architect if you have any questions relating to installation.
- To assure proper installation, it is suggested that a qualified person or registered building practitioner install the Supreme baby change table. SPL (2021) Ltd will not be liable if the unit is not installed properly.
- Any object left on table will become entrapped in mechanism and cause damage when table is closed. Safety of table could be compromised and warranty invalidated.

# Operating Instructions and Parts Manual

Please read all instructions carefully before attempting to install the product described. Protect yourself and others by observing all safety information. Failure to comply with instructions could result in personal injury and / or property damage. Retain instructions for future reference.

## Supreme Baby Change Stainless Surface Mount

Description:

The Supreme Baby Change Table Stainless Steel Surface Mount protrudes ~100mm from the wall and its foldable design provides space optimisation. Adjustable restraint belt helps to protect the safety of baby.

## Specifications

Colour	Stainless Steel
Load Support	Up to 20kgs
Unit Weight	23.9kgs (net)
Material	304 Stainless steel clad and polyethylene internal
Dimensions	905W x 520D x 459D mm (open) 104D (closed)
Standards	Complys with EN12221
Fixing	All fixings included + mounting template
Warranty	12 months

## Planning

Wooden double stud blocking is necessary.

When positioning baby change table, take note of traffic flows in the washroom, also be aware of obstruction doors, cabinets etc.

## Recommended Mounting Heights

There are no fixed or regulated height at which the table is mandated to be fitted. As a guide, we recommend a vertical height from the floor to the changing surface of between 750mm - 850mm.

# Installation Instructions

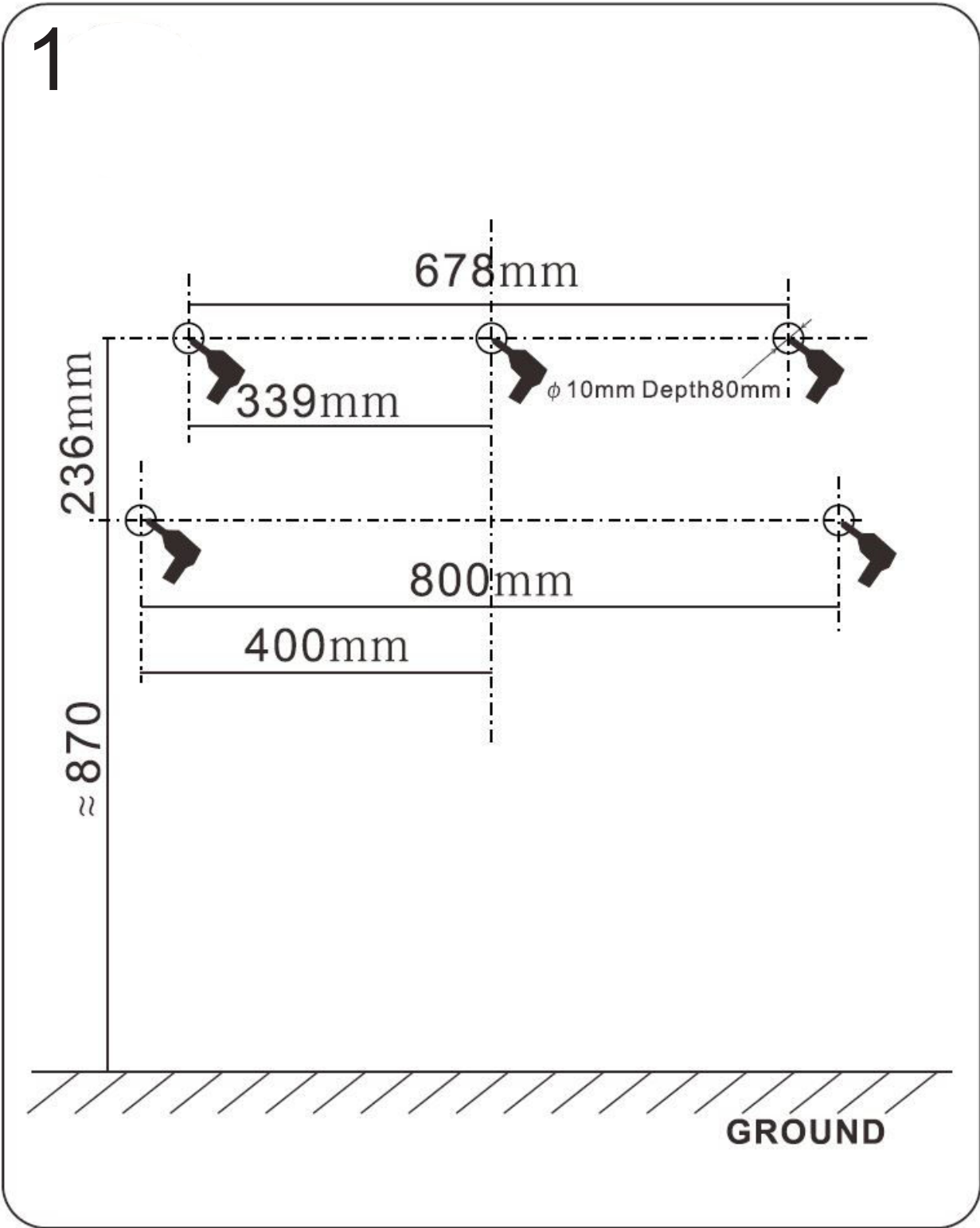

2

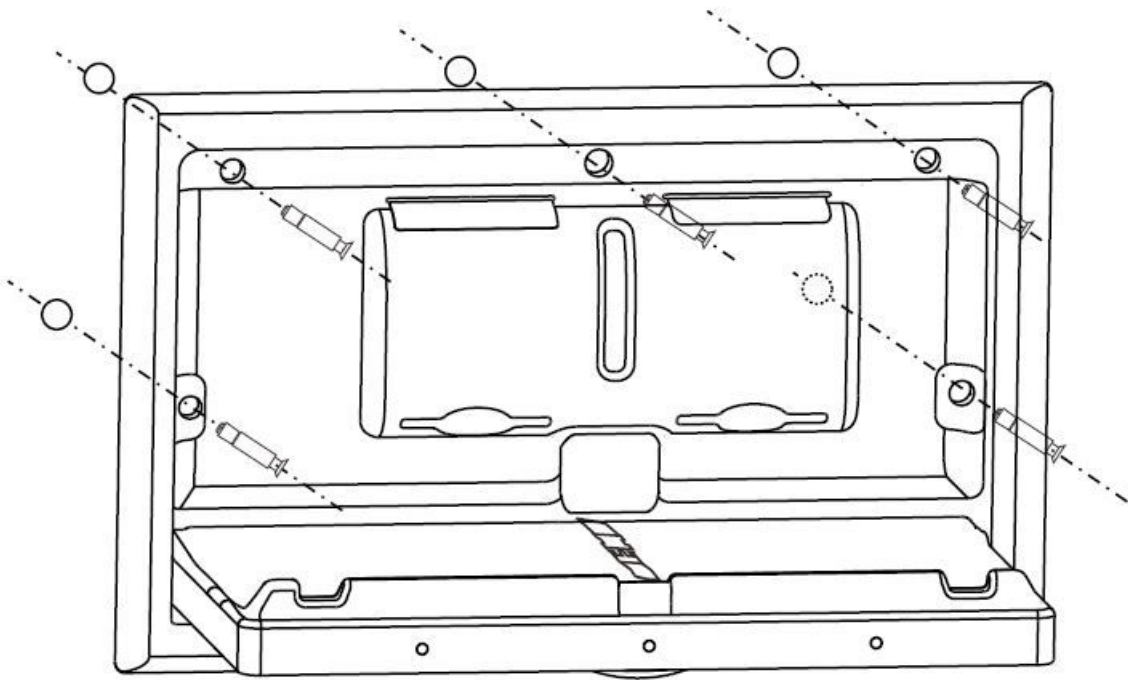

3

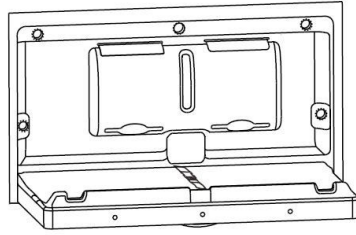

open

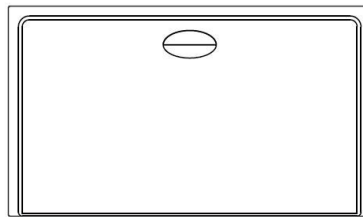
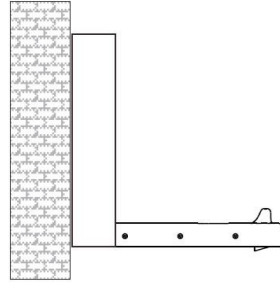

close



# Maintenance Instructions

1. Check all components and hardware monthly or as required. Ensure hardware is tight and there are no missing or damaged components.
2. To clean, use a damp cloth with mild soap or mild multi-purpose cleaner. Do not use strong chemical cleaners or cleaning agents that may be hazardous to children.

Take unit out of service if any components are missing or damaged. Contact SPL to order spare parts. DO NOT substitute parts.

# Supreme Comprehensive Warranty

Your Supreme Baby Change is fully guaranteed against defective materials and faulty workmanship commencing from the date of sale (according to SPL's records), subject to it being installed and maintained in accordance with the manufacturer's instructions.

SPL (2021) Limited warrants that should any part fail within the given warranty period (12 months), it will be remedied by SPL. The change table should be returned to SPL (2021) Limited for all warranty claims. The cost of cartage will be payable by the customer.

This warranty excludes:

- Incorrect installation, or installation that does not specifically follow the installation guidelines supplied
- Failure to follow manufacturer's maintenance instructions
- Damage/Failure resulting from:
  - the use of non-authorized parts
  - authorized parts not installed in accordance with the manufacturer's instructions
  - accidental damage, negligent use, misuse, vandalism, neglect
  - damage caused either directly or indirectly by external sources (natural disaster, or insect infestation)
- Water ingress caused by property maintenance or flooding
- Negligent cleaning practices (harmful chemical etc)

*The above includes consequential damage to any other goods, furnishings, or property.*

- Normal wear and tear and consumable parts
- This warranty does not displace any statutory warranty in relation to the change table but any liability of SPL (2021) Limited under any statutory warranty will be limited to a replacement or repair of the change table or payment of the cost of such replacement or repair at the sole discretion of SPL (2021) Limited

Note: Our Warranty only extends to products purchased and installed in New Zealand.

SPL Limited  
PO Box 437, Cambridge 3450  
New Zealand

p. +64 7 823 5790  
e. [office@splwashrooms.co.nz](mailto:office@splwashrooms.co.nz)