

SUPREME

MASTER FLUSH



Installation
& maintenance
instructions.

General Information

- Designed for indoor use only. Do not expose to the elements of nature.
- All plumbing connections must be made in accordance with AS/NZ3500 and installation with AS/NZ3500.2.
- Master Flush systems should be installed in compliance with all local / national water supply standards.

Warnings

- Read all instructions before attempting to install this system. It is recommended a qualified & registered plumber completes the install.
- Never connect the battery pack directly to solenoid valve.
- Ensure pipe work is thoroughly flushed before installing the solenoid assembly. Solenoid components are susceptible to debris and require additional flushing compared to a standard plumbing fixture.
- Consideration should be given to any regulations relating to an air gap, an air break or double check valve to protect against back flow.

Operating Instructions and Parts Manual

Please read carefully before attempting to assemble, install, operate or maintain the product described. Protect yourself and others by observing all safety information. Failure to comply with instructions could result in personal injury and/or property damage. Retain instructions for future reference.

Supreme Master Flush Urinal Water Control

Passive infrared (PIR) sensors detects and responds to movement engaging flush cycle. Program your flush cycles to suit system and traffic. Suitable for direct feed or cistern feed urinals. Battery or mains powered options.

Specifications

Sensor	Passive infrared (PIR)
Colour	White
Casing	ASB capped acrylic
Power	9V alkaline battery pack OR optional 240V AC (9V DC regulated power pack)
Printed board	Micro chip
Solenoid valve	9V DC latching, 0.3-10 bar pressure (30-1000 KPA), ballofix valve, 15mm male connections
Flushing cycle	Set via learn function, plus pre flush and 6 or 12 hour janitor flush options
Delay before flush	25 sec, 1 min, 5 min, 10 min, or 15min
Dimensions	130 SQ mm x 43D mm - sensor 96W x 150L x 56D - solenoid housing
Warranty	12 months (excludes battery)

Planning

The Supreme Master Flush is suitable for controlling the water flow in direct feed or cistern feed urinals.

Consideration should be given to any regulations relating to an air gap, an air break or double check valve to protect against back flow.

Maintenance

- Keep slot opening on sensor clean and clear of dirt. Never use abrasive cleaners. Use warm soapy water and a soft cloth. Never hose or spray.
- To avoid premature failure it is recommended that the battery pack and solenoid are inspected and cleaned annually.

Typical Piping Arrangements

Typical Installation with Cistern Feed

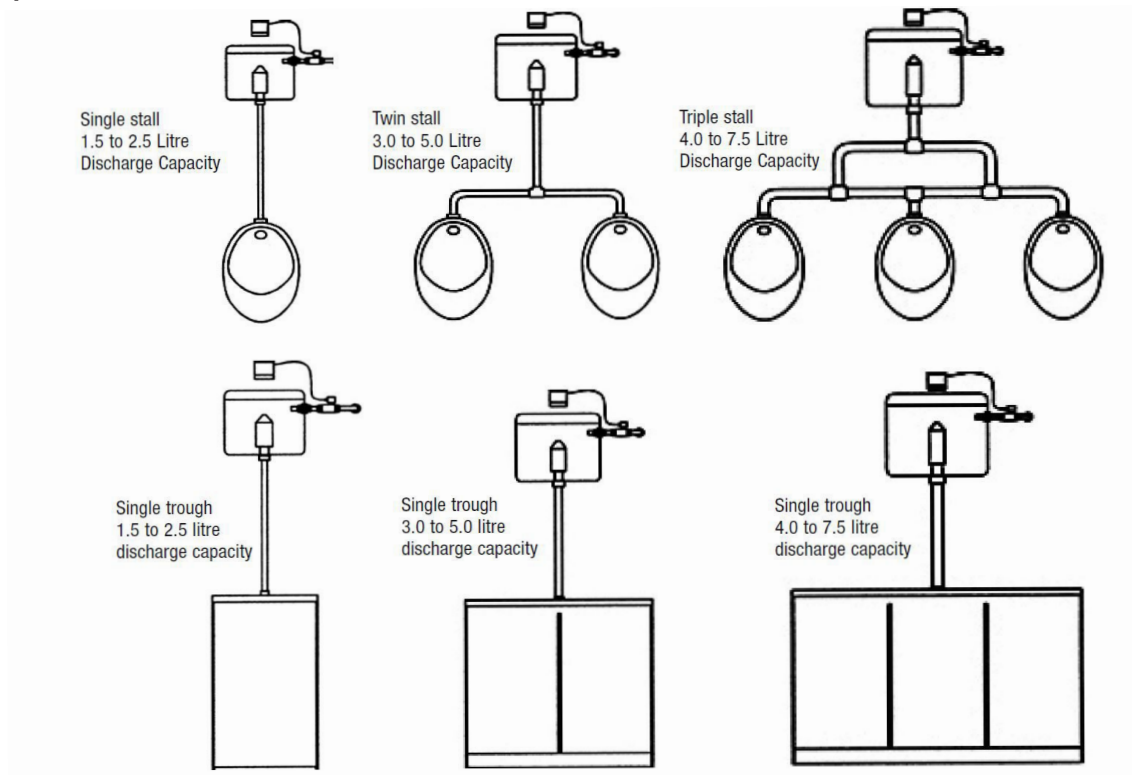

Typical Installation with Direct Feed

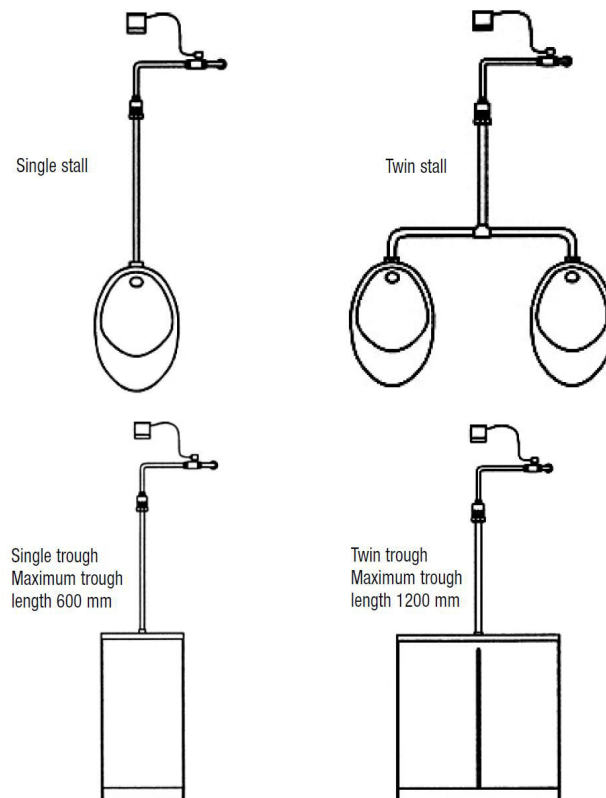

NOTE: Multiple water outlets may require form of water balancing to achieve uniform flushing.

Installation

1. Solenoid (Cistern & Direct Feed)

- i. Isolate water supply. An isolating valve must be installed in accordance with AS/NZ 3500.1
- ii. Identify a suitable position for the solenoid assembly. Position in an upright position (preferably). If cistern, position solenoid as close to cistern as possible.
- iii. Cut the water supply pipe and flush thoroughly to purge swarf and debris. Failure to perform this step may cause the solenoid to become blocked and it will not close.
- iv. Ensure solenoid valve orientation is correct (flow direction is marked on the body of the valve with an arrow).
- v. Fix appropriately to wall or in ceiling cavity.

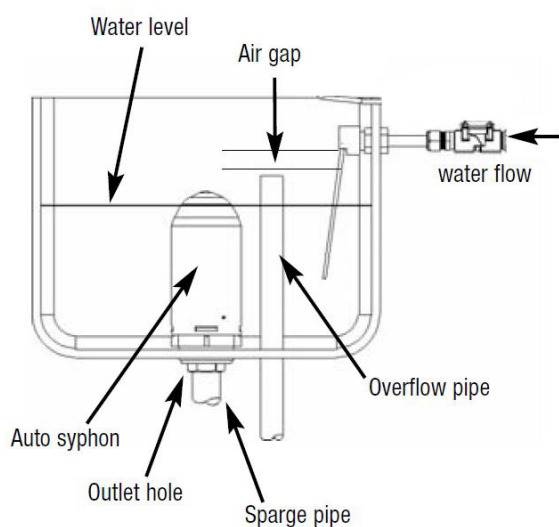

Fig 1. Cistern with autosyphon

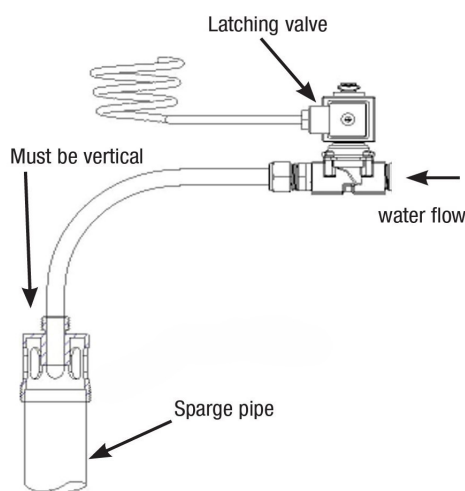

Fig 2. Direct feed

- vi. Turn water on and check for leaks.

IMPORTANT:

- If water pressure exceeds 500KPA or 5bar, install flow restrictor valve (not supplied). Flow restrictor valve must be installed between the isolating valve and solenoid valve.
- If any water hammering present, install hammering arrestor (not supplied). Continued hammering may cause the solenoid to fail and bounce open.
- If solenoid is blocked due to debris and cannot close, check and clean filter.
- If water quality is poor, additional filter protection may be required.
- Cistern - ensure flush triggering level of autosyphon is below water inlet - Fig 1.
 - an air-gap must be present between the cistern water level and the water inlet pipe to prevent back-flow - Fig 1.

2. Sensor (Surface Mounted)

- i. The sensor can be ceiling (preferable) or wall mounted. For optimal performance sensor should be positioned 1 - 1.5m from the urinal (allow traffic to pass through versus standing under)

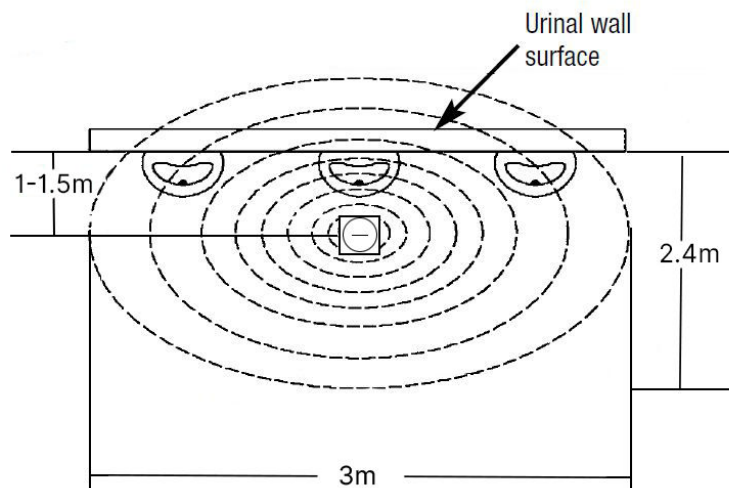

Fig 3. Ceiling Mounted - Note sensor slot (East/West) parallel to the urinal

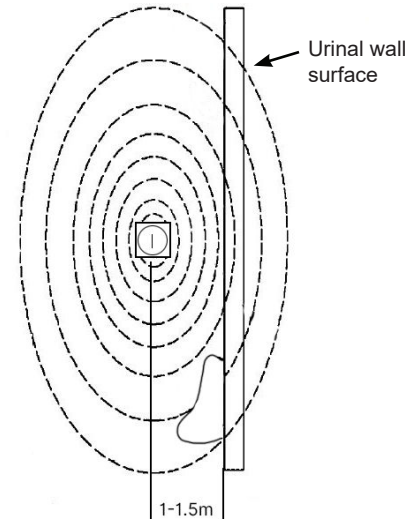

Fig 4. Wall Mounted - Note sensor slot (North/South) parallel to urinal

- ii. For single stall urinal position sensor above centre of stall.
- iii. For double or triple urinal position in centre of stalls.
- iv. If more than 3 urinals, use additional sensors.
- v. When a suitable location has been found, remove mounting plate from sensor unit (magnetic) and fix to ceiling (or wall) using appropriate fixing for substrate. Take note of sensor slot orientation - Fig 3 & Fig 4.

NOTES:

- If mounting on wall ensure sensor slot is orientated North / South. It can also be tilted to capture a greater range of heights - Fig 4.
- Avoid locating sensor near heat sources (hot pipes, radiators, heat emitting lights or where direct sunlight encroaches on sensor lens).
- Additional flex (cable between sensor and solenoid) can be supplied upon request. DO NOT cut and join as polarity is critical to operation.

IMPORTANT:

- Never connect battery or power pack directly to the solenoid valve or until all plumbing connections are completed. Power must be connected last.

3. Connect Solenoid Valve to Sensor

- i. Run the latching valve cable to the sensor. Ideally, this will be within the wall, ceiling cavity or in conduit.
- ii. Do not extend the cable as this will affect correct operation (we can provide more flex if required).
- iii. Once the power is connected, the system operates in default factory settings.

4. Connect Mains Power Supply (optional)

- i. Locate battery holder and battery supplied with the system. If connected, remove the battery.
- ii. Carefully align the power pack outlet cable plug to power inlet plug attached to the printed circuit board.
- iii. Connect power pack to 220-240V 50/60Hz AC power supply (do not turn on).

Set up

1. Turn water on and inspect all connections. Start with isolating valve half open.
2. Separate the two halves of the sensor assembly by removing the 4 x self tapping screws.
3. Affix battery pack (or power pack if mains) to the back cover and pass solenoid lead through hole.
4. Connect the solenoid lead and battery to the printed circuit board (PCB) - Fig 5.
5. Program flush cycle. See page 8 for further details.
6. Reassemble the controller.
7. Attach to ceiling plate via back plate magnets.

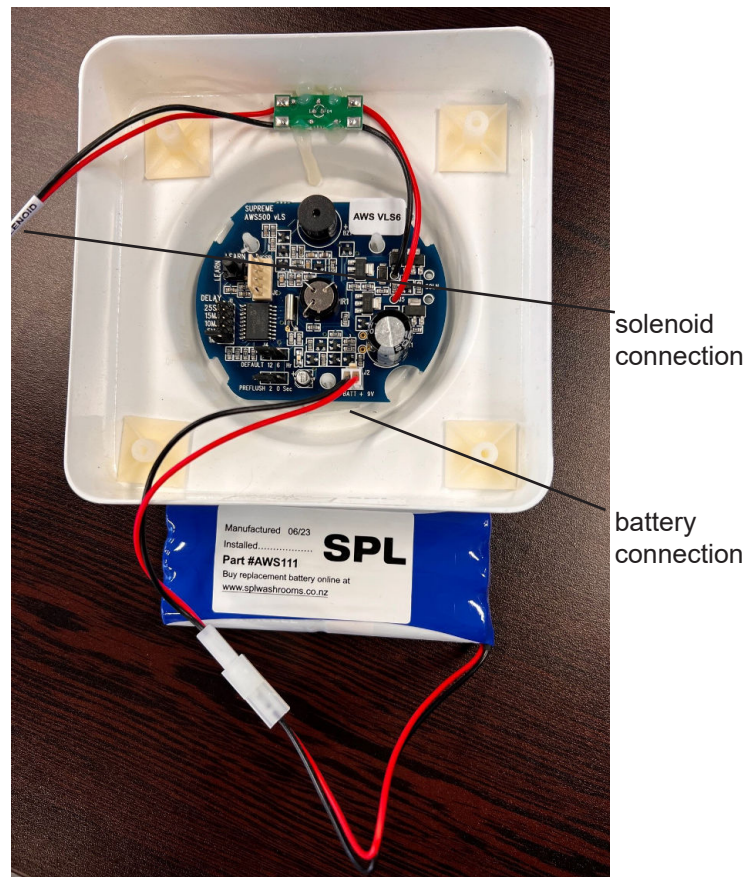

Fig 5. Battery connection connects to mains adapter if applicable

Programming Flush Cycles

Direct Feed Urinals

1. Set the pre-flush to “2” (jumpers hard left) - See page 9.
2. Select time delay before flush. We suggest 1 minute.
3. Select janitor flush time (either 6 or 12 hours).
4. PUSH & RELEASE the learn button to start flow of water (green LED flash).
5. When sufficient water has flowed to clear the urinal PUSH & RELEASE the learn button again to stop the water flowing (amber LED flash).
6. Your flush cycle is now set.

IMPORTANT: The flushing volume of water should not exceed the volume the sparge pipe (and urinal) can flush to avoid flooding during fault and / or blockages.

Cistern Feed Urinals

It has been assumed that the cistern will be fitted with an auto syphon.



1. Set the pre-flush to “0” (jumpers hard right) - See page 9.
2. Select a time delay before flush. Options range from 25 sec to 15 min.
3. Select janitor flush time (either 6 or 12 hours).
4. With the cistern empty, PUSH & RELEASE the learn button to start flow of water (green LED flash).
5. Continue filling until the auto syphon system starts to flush. Count 1001, 1002, 1003 then PUSH & RELEASE the learn button again to stop the water flow (amber LED flash). The fill cycle should over-run the flush by a few seconds to allow for pressure fluctuations.
6. Your flush cycle is now set.

IMPORTANT:

- You should not have a volume of water entering the cistern greater than the sparge pipe (and urinal) can flush. This is to safeguard against a possible overflow of the cistern under fault conditions.
- With cistern set up, sensor will not flash on detection and will flash once chosen delay period has past and solenoid opens.
- The maximum available flush time is 7 minutes.

Explanation of Master Flush Features

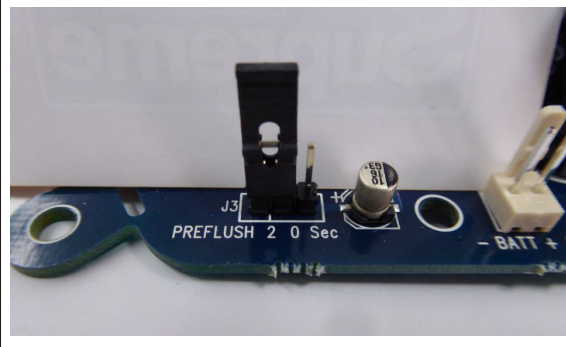
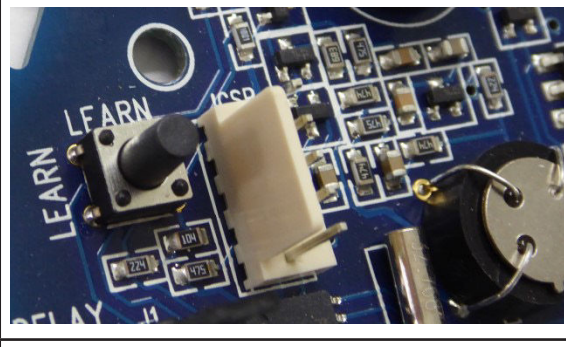
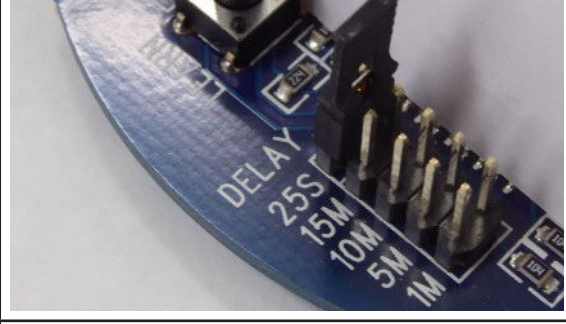
The controller has a number of features to allow customisation

	<p>PRE-FLUSH The pre-flush option gives the urinal a quick two second rinse when the urinal sensor is activated and is usually followed by a one minute delay before the full flush. This feature is commonly utilised for direct feed urinal installations but can be deactivated for cistern feed by moving the jumpers hard right.</p>
	<p>LEARN BUTTON The learn button is used to set the length of time the solenoid is open (flush time). PUSH & RELEASE once to open the valve (green flash). PUSH & RELEASE again to shut the valve after the desired flush time (amber flash). This time is memorised and will become your flush time.</p>
	<p>DELAY This is commonly used to reduce water usage by introducing a delay after activation but before the flush cycle. Examples of its use are in peak times in schools or sporting venues.</p>
	<p>DEFAULT FLUSH The default flush will activate either 6 or 12 hourly after the last activation. Selection can be made via moving the jumpers hard left of hard right accordingly. This feature has been incorporated to keep the urinal fresh during periods of inactivity and cannot be disabled completely.</p>
<p>LOW BATTERY WARNING</p>	<p>When the battery pack voltage drops to a pre determined level, a chirp is heard on activation. The battery pack should be replaced.</p>
<p>LED LIGHTS</p>	<p>LED bi-colour lights are fitted to both the sensor and solenoid. These will simultaneously flash green for solenoid valve open and amber for valve closed.</p>

Troubleshooting

There are 3 generation models of Supreme Master Flush. If spare parts are required visit splwashrooms.co.nz/product/flush-parts

Symptom	Possible Issue / Fix	Remedy
Sensor unit is making a chirping sound	<ul style="list-style-type: none"> a. Battery voltage dropped b. Mains power failed 	<ul style="list-style-type: none"> a. Replace battery (AWS111) visit splwashrooms.co.nz b. Ensure power supply at source
Sensor unit not detecting occupants	<ul style="list-style-type: none"> a. Battery flat or power outage at source b. Plugs not connected correctly and or corrosion present (including PCB) c. Lens slot in sensor blocked / dirty d. Heat sources present in detection zone? (heat emitting lights, pipes etc) e. Sensor positioned correctly? f. Faulty sensor unit 	<ul style="list-style-type: none"> a. Replace battery or ensure mains power supply at source b. Unplug and work all terminals. Clean with isopropyl alcohol c. Clean with soft cloth d. Relocate sensor away from heat sources - see page 6 e. Reposition sensor – see page 6 f. Replace sensor PCB
Solenoid valve not opening and or closing	<ul style="list-style-type: none"> a. Battery voltage has dropped or mains power failed b. Sensor not activating? c. Check cable from PCB. Has it extended? d. Installed in correct orientation? e. Debris present / blockage f. Water pressure too high g. Water hammering present? h. Faulty solenoid 	<ul style="list-style-type: none"> a. Check power source & all connections b. Check sensor position as above c. Ensure polarity is correct. We can provide cable extensions d. Water inlet / outlet as per arrows e. Clean solenoid filter f. Check water pressure & install flow restrictor if necessary g. Install hammer arrestor h. Replace solenoid valve
Water is trickling / dribbling when solenoid valve is open	<ul style="list-style-type: none"> a. Solenoid diaphragm split or debris present / blockage b. Water pressure adequate? 	<ul style="list-style-type: none"> a. Replace diaphragm or solenoid b. Clean all filters including solenoid filter c. Ensure adequate water pressure
Water is running for too short or too long	<ul style="list-style-type: none"> a. Water pressure / flow change b. Debris limiting flow 	<ul style="list-style-type: none"> a. Refresh learn time - refer to page 8 b. Clean filters on all valves
Cistern under or over fills	<ul style="list-style-type: none"> a. Water pressure change b. Debris limiting flow 	<ul style="list-style-type: none"> a. Refresh learn time - refer to page 8 b. Clean filters on all valves

Advanced Problem Solving

When the learn button is pushed and released (to open and close the valve) the LED's at the sensor and the solenoid valve should flash simultaneously.

- If the both LED's flash and you can hear the solenoid trying to shut or click – ensure there is water at the source and the solenoid is clear of debris. If this fails to resolve – replace solenoid valve.
- If the LED flashes at the sensor, but not the solenoid valve – check connection and cable between sensor and solenoid, including polarity. If this fails to resolve – replace solenoid valve.
- If there is no LED flash at the sensor – ensure there is power, all connections are correct and no signs of corrosion. If this fails to resolve – replace the printed circuit board (PCB).

Supreme Comprehensive Warranty

Your Supreme Master Flush is fully guaranteed against defective materials and faulty workmanship commencing from the date of sale (according to SPL's records), subject to it being installed and maintained in accordance with the manufacturer's instructions.

SPL (2021) Limited warrants that should any part of the unit fail within the given warranty period (12 months), it will be remedied by SPL.

Due to the significant variation in tradesmen's knowledge, experience, and productivity, labour charges will NOT be accepted unconditionally. We strongly recommend contacting our office for advice before proceeding with any warranty repairs.

This warranty excludes:

- Incorrect installation, or installation that does not specifically follow the installation guidelines supplied
- Defects arising from improper installation, or incorrect electrical supply where applicable
- Failure to follow manufacturer's maintenance instructions
- Damage/Failure resulting from:
 - the use of non-authorized parts
 - authorized parts not installed in accordance with the manufacturer's instructions
 - accidental damage, negligent use, misuse, vandalism, neglect
 - damage caused either directly or indirectly by external sources (power outages, power surges, incorrect power supply, natural disaster, or insect infestation)
- Water ingress caused by property maintenance or flooding
- Failure due to contamination (pipe work should be flushed before installing the solenoid assembly.)

The above includes consequential damage to any other goods, furnishings, or property.

- Normal wear and tear and consumable parts (batteries etc)
- This warranty does not displace any statutory warranty in relation to the unit but any liability of SPL (2021) Limited under any statutory warranty will be limited to a replacement or repair of the unit or payment of the cost of such replacement or repair at the sole discretion of SPL (2021) Limited

Note:

- Warranty only extends to products purchased and installed in New Zealand.
- Contamination or poor water quality is not covered by product warranty.
- Damage to solenoid caused by inadequate flushing or excess water pressure is not covered by the product warranty.

SPL Limited
Cambridge 3434
New Zealand

p. +64 7 823 5790
e. office@splwashrooms.co.nz